

# APG023N10D7

## N-Channel Enhancement Mosfet

### Features

- 100V,280A  
 $R_{DS(ON)} < 2.3m\Omega @ V_{GS}=10V$  TYP:2.0m $\Omega$
- Surface-mounted package
- Advanced trench cell design

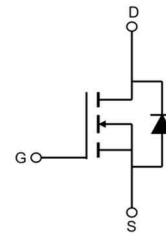

Schematic Diagram

### Applications

- High power inverter system
- LCD TV appliances
- LCDM appliances

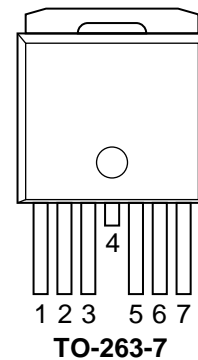

### Package Marking and Ordering Information

Device Marking	Device	Device Package	Reel Size	Tape width	Quantity (PCS)
G023N10D7	APG023N10D7	TO-263-7	-	-	800

### ABSOLUTE MAXIMUM RATINGS ( $T_J=25^\circ\text{C}$ unless otherwise noted)

Parameter	Symbol	Value	Unit
Drain-Source Voltage	$V_{DS}$	100	V
Gate-Source Voltage	$V_{GS}$	$\pm 20$	V
Continuous Drain Current ( $T_c=25^\circ\text{C}$ ) <sup>(1)</sup>	$I_D$	280	A
Continuous Drain Current ( $T_c=100^\circ\text{C}$ ) <sup>(1)</sup>	$I_D$	200	A
Pulsed Drain Current <sup>(1)</sup>	$I_{DM}$	1000	A
Single Pulsed Avalanche Energy ( $T_c=25^\circ\text{C}, L=0.1\text{mH}$ )	$E_{AS}$	1750	mJ
Drain Power Dissipation	$P_D$	286	W
Thermal Resistance from Junction to Case <sup>(2)</sup>	$R_{\theta JC}$	0.25	$^\circ\text{C}/\text{W}$
Thermal Resistance- Junction to Ambient <sup>(2)</sup>	$R_{\theta JA}$	40	$^\circ\text{C}/\text{W}$
Junction Temperature	$T_J$	175	$^\circ\text{C}$
Storage Temperature	$T_{STG}$	-55~ +175	$^\circ\text{C}$

Notes:

1. Pulse width  $\leq 300\mu\text{s}$ , duty cycle  $\leq 2\%$
2. Surface Mounted on minimum footprint pad area
3. Limited by bonding wire

**MOSFET ELECTRICAL CHARACTERISTICS(T<sub>J</sub>=25°C unless otherwise noted)**

Parameter	Symbol	Test Condition	Min	Type	Max	Unit
<b>Static Characteristics</b>						
Drain-source breakdown voltage	V <sub>(BR)DSS</sub>	V <sub>GS</sub> = 0V, I <sub>D</sub> =250μA	100	-	-	V
Zero gate voltage drain current	I <sub>DSS</sub>	V <sub>DS</sub> =80V, V <sub>GS</sub> = 0V	-	-	1	μA
Gate-body leakage current	I <sub>GSS</sub>	V <sub>GS</sub> = ±20V, V <sub>DS</sub> = 0V	-	-	±100	nA
Gate threshold voltage	V <sub>GS(th)</sub>	V <sub>DS</sub> =V <sub>GS</sub> , I <sub>D</sub> =250μA	2.0	-	4.0	V
Drain-source on-resistance <sup>(a)</sup>	R <sub>DS(on)</sub>	V <sub>GS</sub> =10V, I <sub>D</sub> =20A	-	2.0	2.3	mΩ
<b>Dynamic characteristics<sup>(b)</sup></b>						
Input Capacitance	C <sub>iss</sub>	V <sub>DS</sub> =50V, V <sub>GS</sub> =0V, f =1.0MHz	-	7884	-	pF
Output Capacitance	C <sub>oss</sub>		-	1240	-	
Reverse Transfer Capacitance	C <sub>rss</sub>		-	30	-	
<b>Switching characteristics<sup>(b)</sup></b>						
Turn-on delay time	t <sub>d(on)</sub>	V <sub>DD</sub> =50V, I <sub>D</sub> =20A, R <sub>G</sub> =4.5Ω, V <sub>G</sub> =10V, R <sub>L</sub> =2.5Ω	-	26	-	nS
Turn-on rise time	t <sub>r</sub>		-	55	-	
Turn-off delay time	t <sub>d(off)</sub>		-	72	-	
Turn-off fall time	t <sub>f</sub>		-	66	-	
Total Gate Charge	Q <sub>g</sub>	V <sub>DS</sub> =50V, I <sub>D</sub> =20A, V <sub>GS</sub> =10V	-	122	-	nC
Gate-Source Charge	Q <sub>gs</sub>		-	32	-	
Gate-Drain Charge	Q <sub>gd</sub>		-	31	-	
<b>Source-Drain Diode characteristics</b>						
Diode Forward voltage <sup>(a)</sup>	V <sub>SD</sub>	T <sub>J</sub> =25°C, V <sub>GS</sub> =0V, I <sub>S</sub> =20A	-	-	1.3	V
Diode Forward current	I <sub>S</sub>	T <sub>C</sub> =25°C	-	-	280	A
Body Diode Reverse Recovery Time	t <sub>rr</sub>	T <sub>J</sub> =25°C, I <sub>F</sub> =20A, di/dt=100A/us	-	96	-	nS
Body Diode Reverse Recovery Charge	Q <sub>rr</sub>	T <sub>J</sub> =25°C, I <sub>F</sub> =20A, di/dt=100A/us	-	235	-	nC

**Notes:**

- a) Pulse width ≤ 300 μs, duty cycle ≤ 2%
- b) Guaranteed by design, not subject to production testing

**Test Circuit**

Gate Charge Test Circuit & Waveform

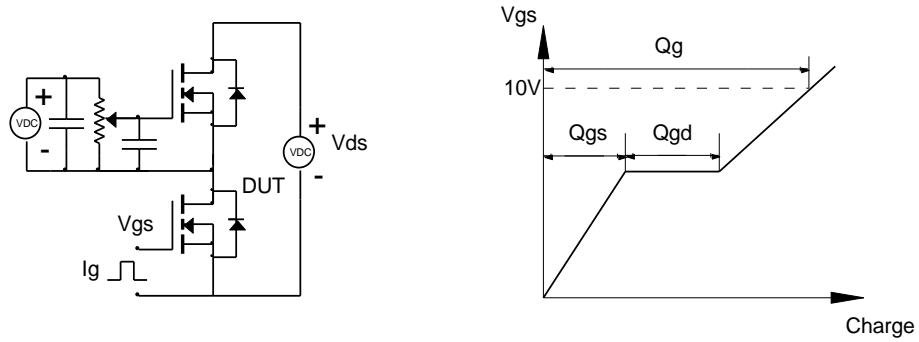

Resistive Switching Test Circuit & Waveforms

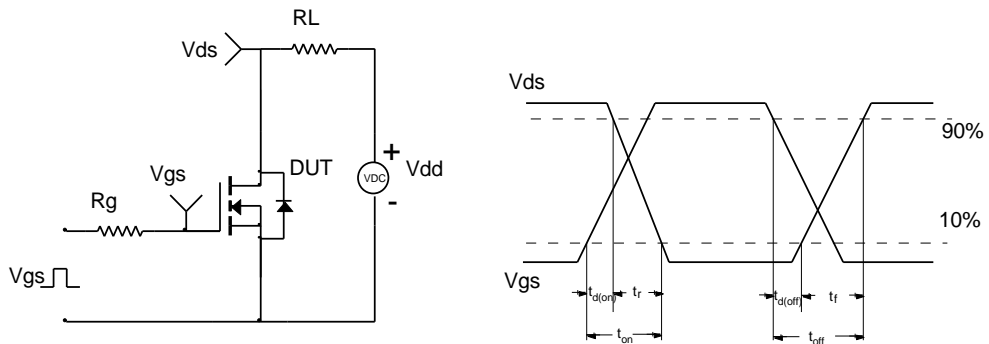

Unclamped Inductive Switching (UIS) Test Circuit & Waveforms

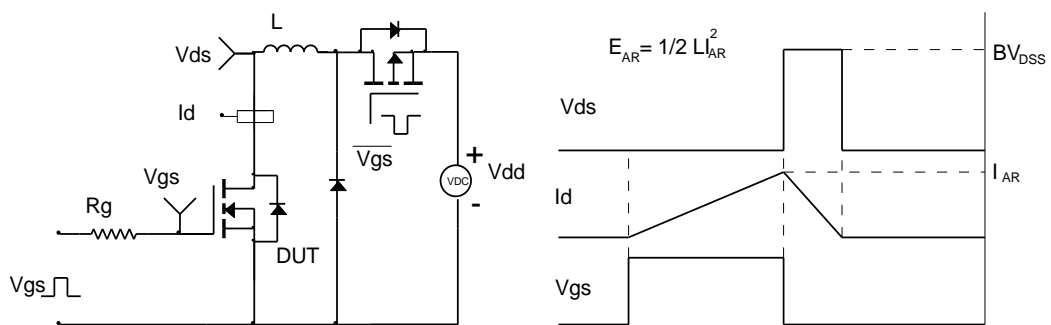

Diode Recovery Test Circuit & Waveforms

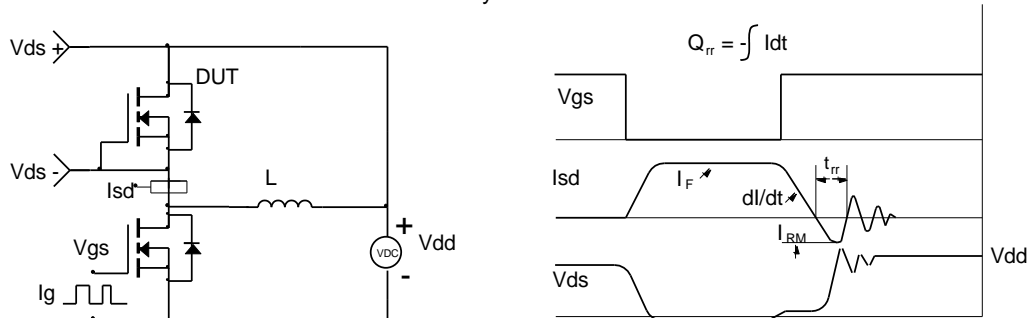

### Typical Characteristics

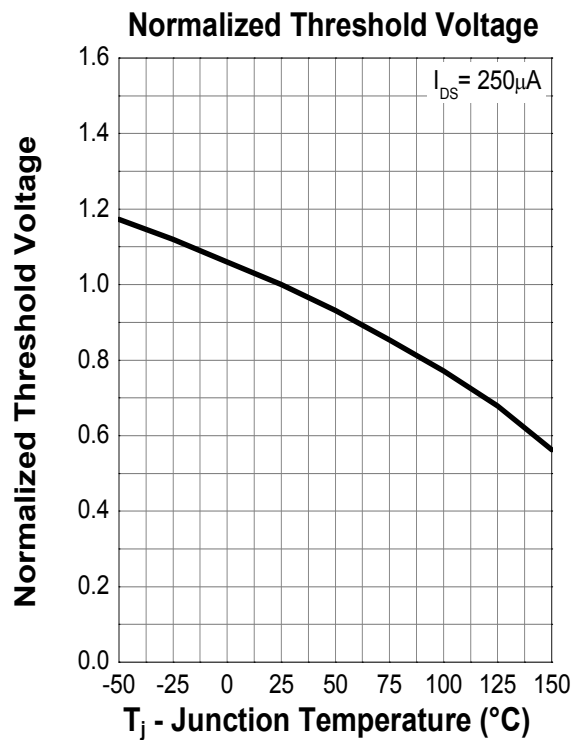
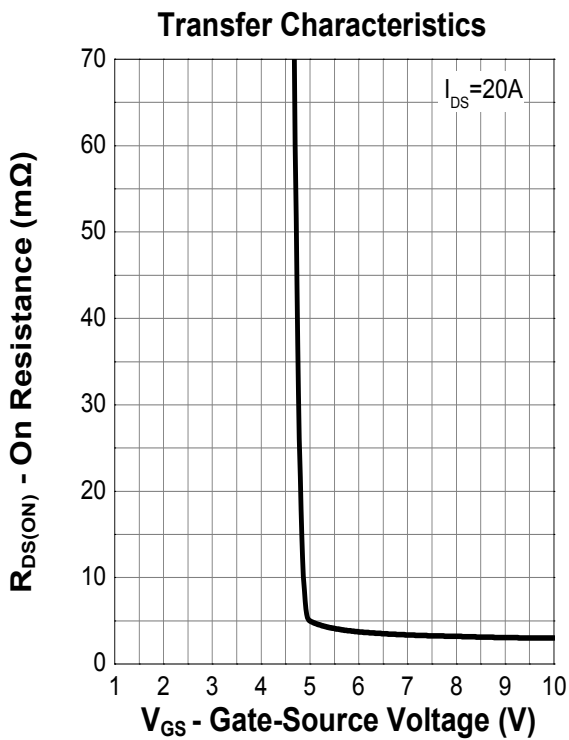
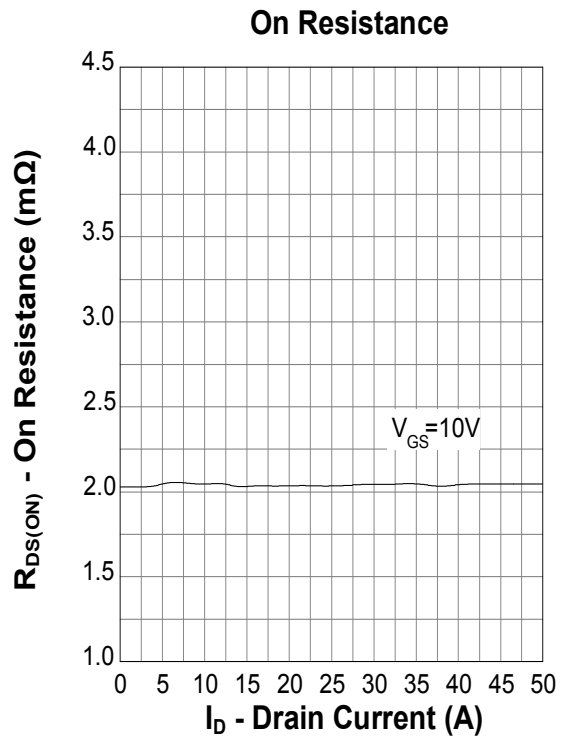
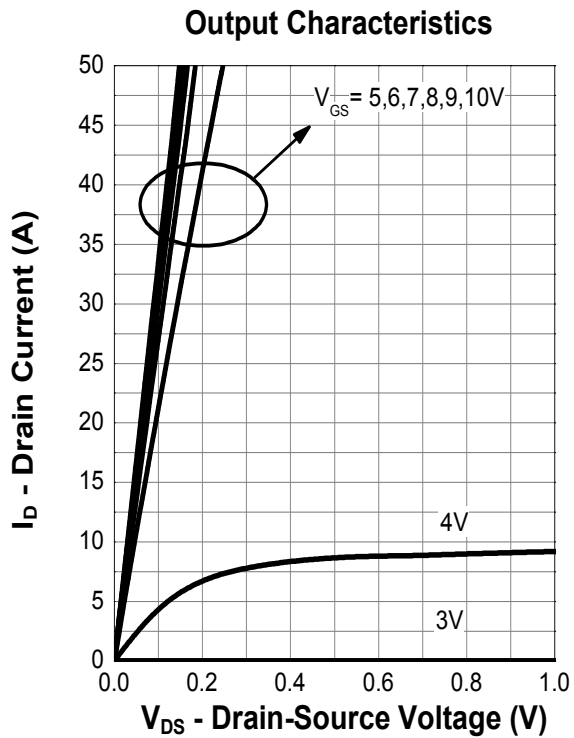

### Typical Characteristics

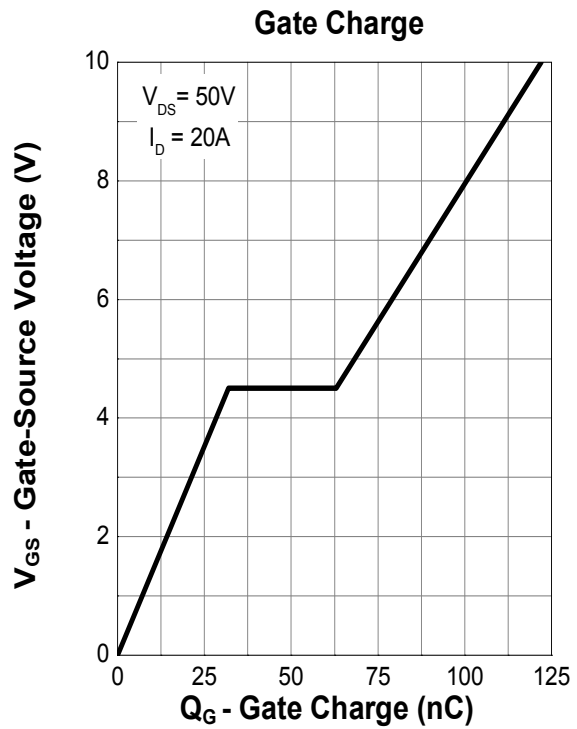
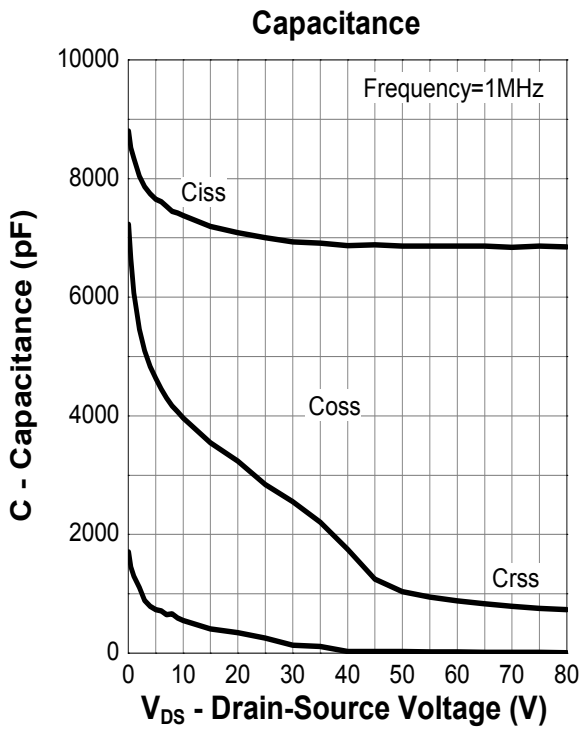
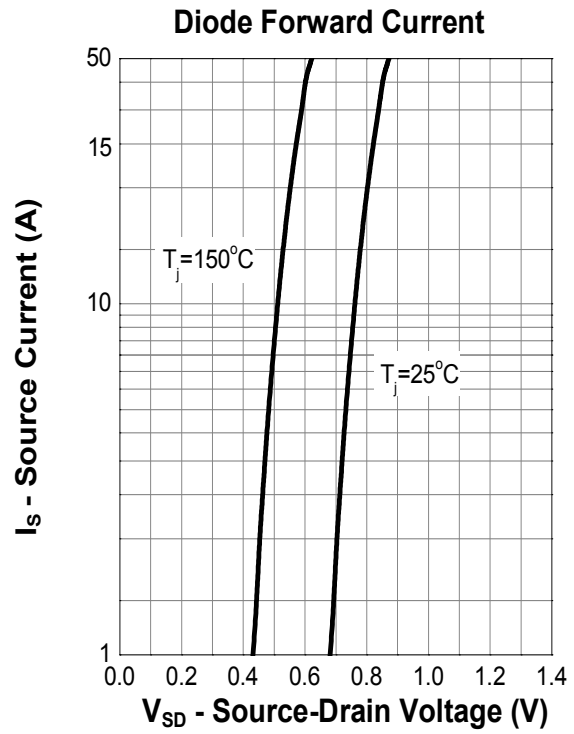
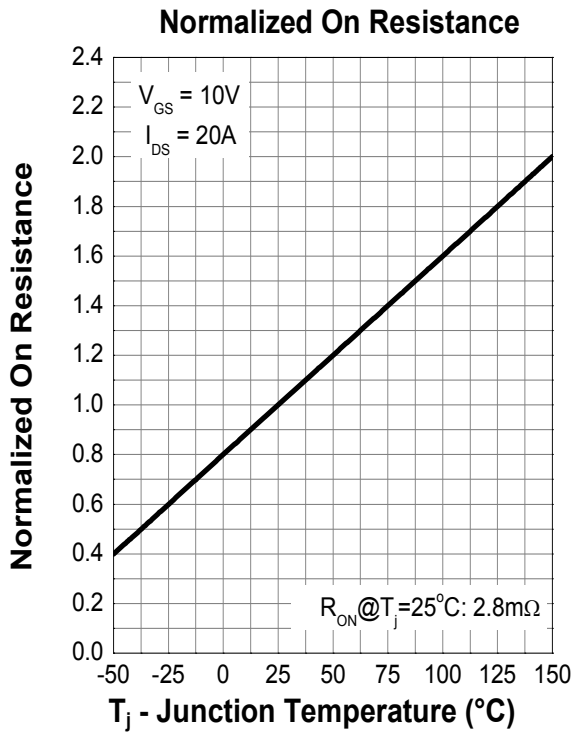

**Typical Characteristics**

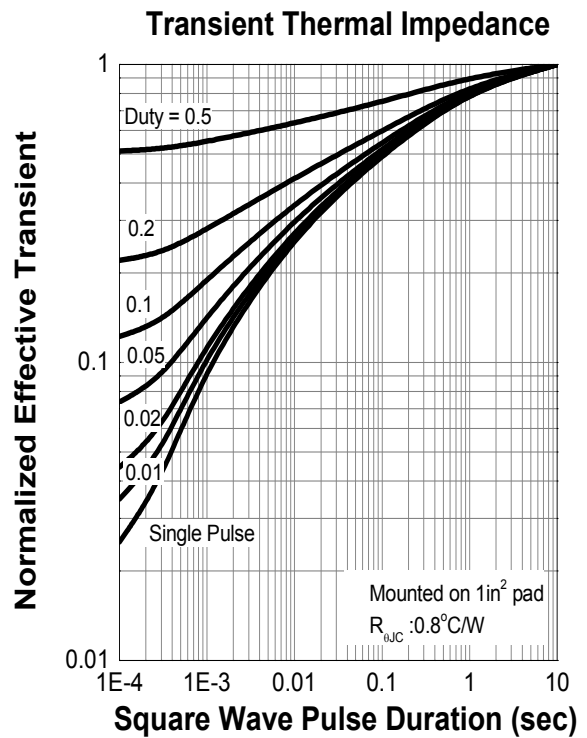
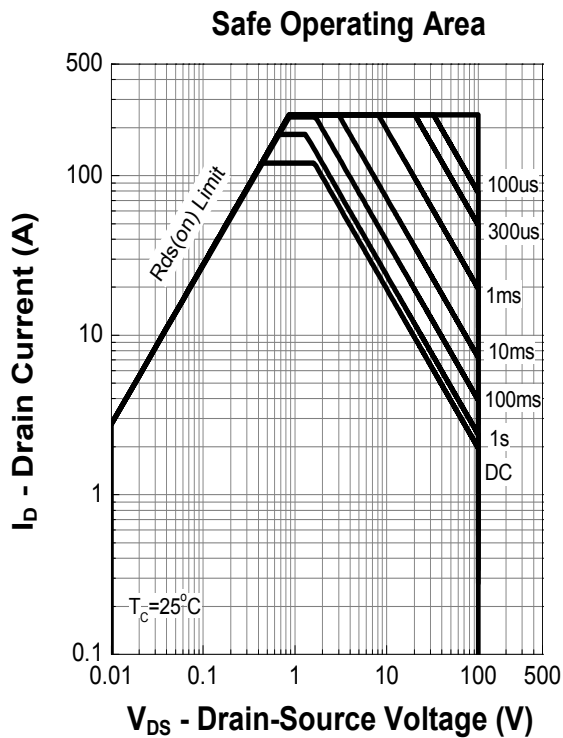
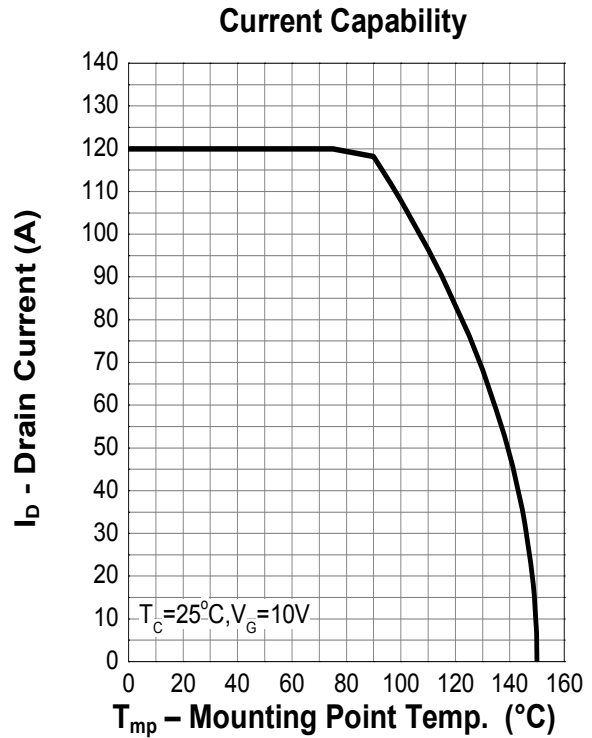
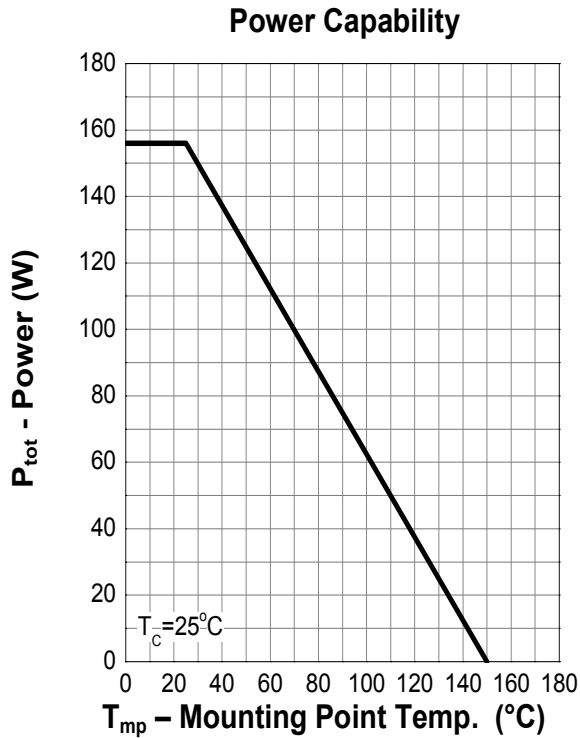

## Package Dimensions

### TO-263-7

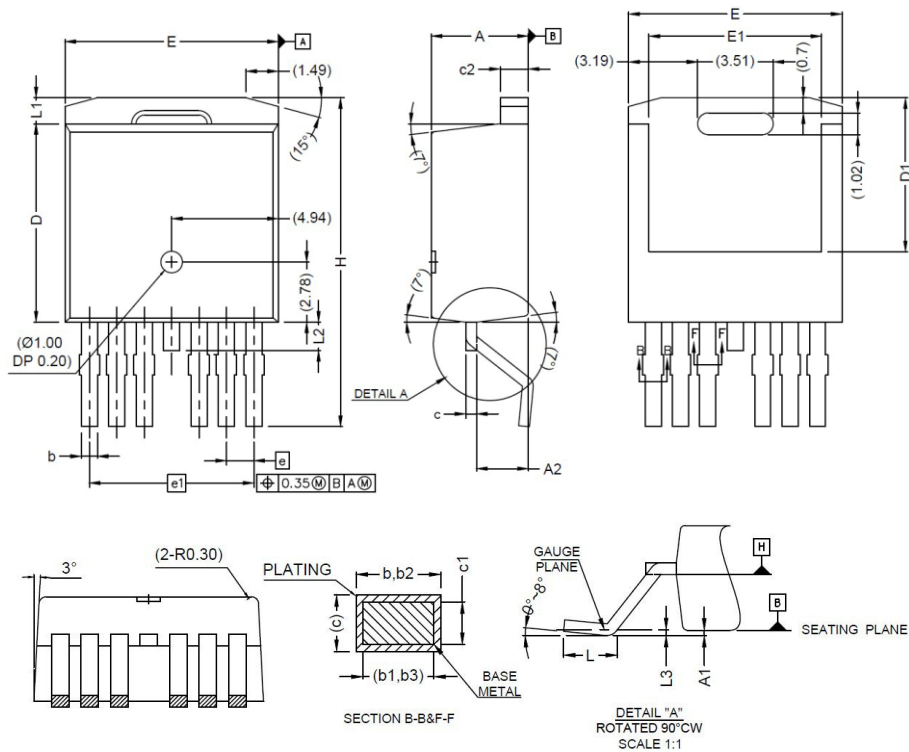

Symbol	Dimensions In Millimeters	
	MIN.	MAX.
A	4.30	4.70
A1	-	0.25
A2	2.20	2.60
b	0.65	0.85
b1	0.65	0.80
b2	0.80	1.00
b3	0.80	0.95
c	0.45	0.60
c1	0.45	0.55
c2	1.25	1.40
D	9.00	9.40
D1	6.86	7.42
E	9.68	10.08
E1	7.70	8.30
e	1.27 BSC	
e1	7.62 BSC	
L	1.78	2.79
L1	-	1.60
L2	-	1.78
L3	0.25 BSD	
H	14.61	15.88

## Revision History

Revision	Release	Remark
V1.0	2023/03/07	Initial Release

## Disclaimer

The information given in this document describes the independent performance of the product, but similar performance is not guaranteed under other working conditions, and cannot be guaranteed when installed with other products or equipment. To achieve the required performance of the product in actual scenarios, the customer should conduct a complete application test to assess the functionality of the product.

Allpower assumes no responsibility for equipment failures result from using products at values that exceed the ratings, operating conditions, or other parameters listed in the product specifications.

The product described in this specification is not applicable for aerospace or other applications which requires high reliability. Customers using or selling these products for use in medical, life-saving, or life-sustaining applications do so at their own risk and agree to fully indemnify.

Due to product or technical improvements, the information described or contained herein may be changed without prior notice.