

APG012N08D7

N-Channel Enhancement Mosfet

Features

- 85V,300A
 $R_{DS(ON)} < 1.2m\Omega @ V_{GS}=10V$ TYP:1.0m Ω
 $R_{DS(ON)} < 1.5m\Omega @ V_{GS}=8V$ TYP:1.3m Ω
 $R_{DS(ON)} < 2.0m\Omega @ V_{GS}=6V$ TYP:1.6m Ω
- Surface-mounted package
- Super Trench
- MSL1

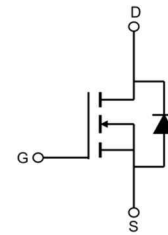

Schematic Diagram

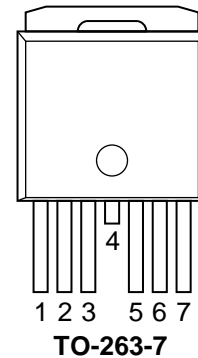

Applications

- E-Tool appliances
- Hard Switching and High Speed Circuit
- BMS appliances
- Inverter appliances

Package Marking and Ordering Information

Device Marking	Device	Device Package	Reel Size	Tape width	Quantity (PCS)
G012N08D7	APG012N08D7	TO-263-7L	-	-	800

ABSOLUTE MAXIMUM RATINGS ($T_J=25^\circ\text{C}$ unless otherwise noted)

Parameter	Symbol	Value	Unit	
Drain-Source Voltage	V_{DS}	85	V	
Gate-Source Voltage	V_{GS}	± 20	V	
Continuous Drain Current	I_D	$T_C=25^\circ\text{C}$	300	A
		$T_C=100^\circ\text{C}$	267	A
Pulsed Drain Current ⁽¹⁾	I_{DM}	1200	A	
Single Pulsed Avalanche Energy ($T_C=25^\circ\text{C}, L=0.5\text{mH}$)	E_{AS}	2800	mJ	
Drain Power Dissipation	P_D	277	W	
Thermal Resistance from Junction to Case ⁽²⁾	$R_{\theta JC}$	0.45	$^\circ\text{C/W}$	
Thermal Resistance- Junction to Ambient ⁽²⁾	$R_{\theta JA}$	32	$^\circ\text{C/W}$	
Junction Temperature	T_J	150	$^\circ\text{C}$	
Storage Temperature	T_{STG}	-55~ +150	$^\circ\text{C}$	

Notes:

- 1.Pulse width $\leq 300\mu\text{s}$, duty cycle $\leq 2\%$
- 2.Limited by bonding wire
- 3.Surface Mounted on minimum footprint pad area

MOSFET ELECTRICAL CHARACTERISTICS($T_J=25^\circ\text{C}$ unless otherwise noted)

Parameter	Symbol	Test Condition	Min	Type	Max	Unit
Static Characteristics						
Drain-source breakdown voltage	$V_{(BR)DSS}$	$V_{GS} = 0V, I_D = 250\mu A$	85	95	-	V
Zero gate voltage drain current	I_{DSS}	$V_{DS} = 80V, V_{GS} = 0V$	-	-	1	μA
Gate-body leakage current	I_{GSS}	$V_{GS} = \pm 20V, V_{DS} = 0V$	-	-	± 100	nA
Gate threshold voltage	$V_{GS(th)}$	$V_{DS} = V_{GS}, I_D = 250\mu A$	2.0	-	4.0	V
Drain-source on-resistance ^(a)	$R_{DS(on)}$	$V_{GS} = 10V, I_D = 50A$	-	1.0	1.2	m Ω
		$V_{GS} = 8V, I_D = 50A$	-	1.3	1.5	m Ω
		$V_{GS} = 6V, I_D = 50A$	-	1.6	2.0	m Ω
Dynamic characteristics^(b)						
Input Capacitance	C_{iss}	$V_{DS} = 50V, V_{GS} = 0V, f = 1.0MHz$	-	14490	-	pF
Output Capacitance	C_{oss}		-	2350	-	
Reverse Transfer Capacitance	C_{rss}		-	472	-	
Switching characteristics^(b)						
Turn-on delay time	$t_{d(on)}$	$V_{DD} = 50V, I_D = 50A, R_G = 4.5\Omega,$ $V_G = 10V, R_L = 1\Omega$	-	39	-	nS
Turn-on rise time	t_r		-	122	-	
Turn-off delay time	$t_{d(off)}$		-	115	-	
Turn-off fall time	t_f		-	137	-	
Total Gate Charge	Q_g	$V_{DS} = 50V, I_D = 50A,$ $V_{GS} = 10V$	-	240	-	nC
Gate-Source Charge	Q_{gs}		-	56	-	
Gate-Drain Charge	Q_{gd}		-	60	-	
Source-Drain Diode characteristics						
Diode Forward voltage ^(a)	V_{SD}	$T_J = 25^\circ\text{C}, V_{GS} = 0V, I_S = 50A$	-	-	1.2	V
Diode Forward current	I_S	$T_C = 25^\circ\text{C}$	-	-	300	A
Body Diode Reverse Recovery Time	t_{rr}	$T_J = 25^\circ\text{C}, I_F = 50A, di/dt = 100A/\mu s$	-	120	-	nS
Body Diode Reverse Recovery Charge	Q_{rr}	$T_J = 25^\circ\text{C}, I_F = 50A, di/dt = 100A/\mu s$	-	360	-	nC

Notes:

- a) Pulse width $\leq 300 \mu s$, duty cycle $\leq 2\%$
b) Guaranteed by design, not subject to production testing

Test Circuit

Gate Charge Test Circuit & Waveform

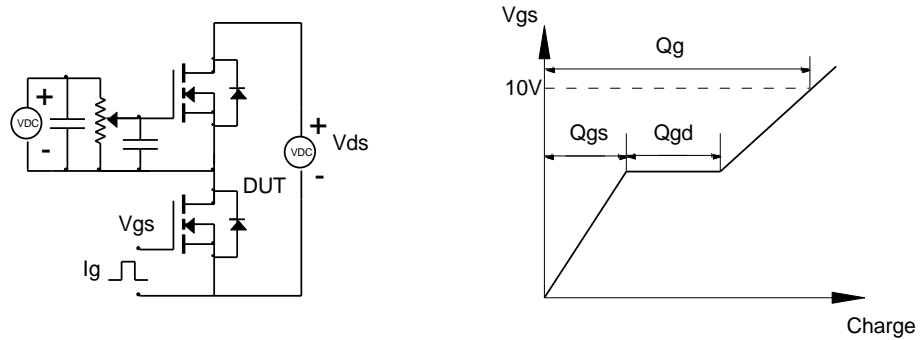

Resistive Switching Test Circuit & Waveforms

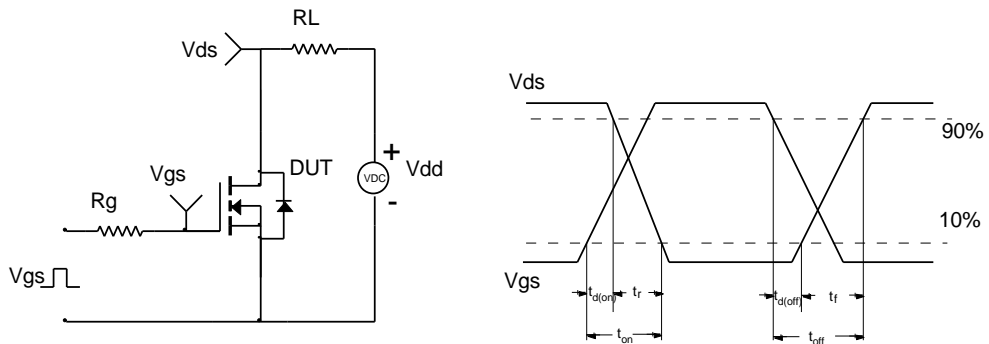

Unclamped Inductive Switching (UIS) Test Circuit & Waveforms

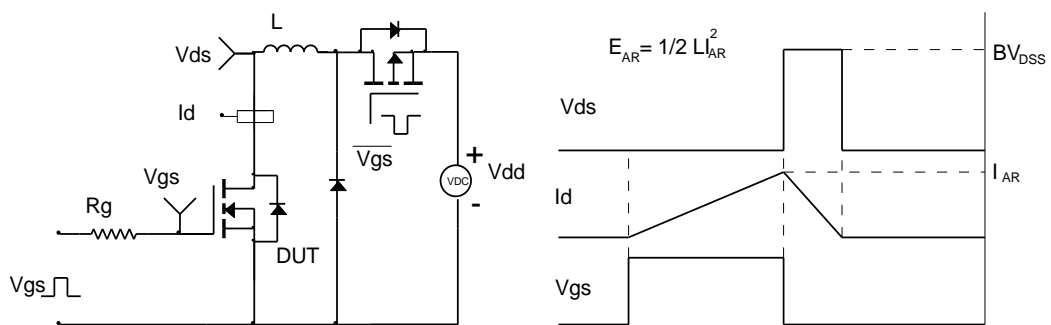

Diode Recovery Test Circuit & Waveforms

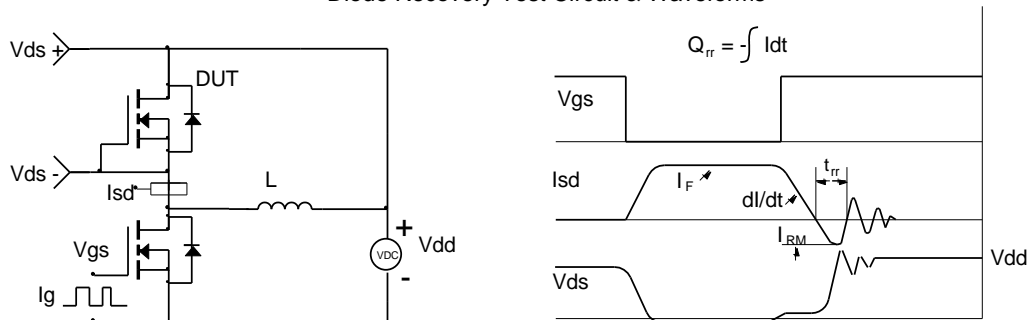

Typical Characteristics

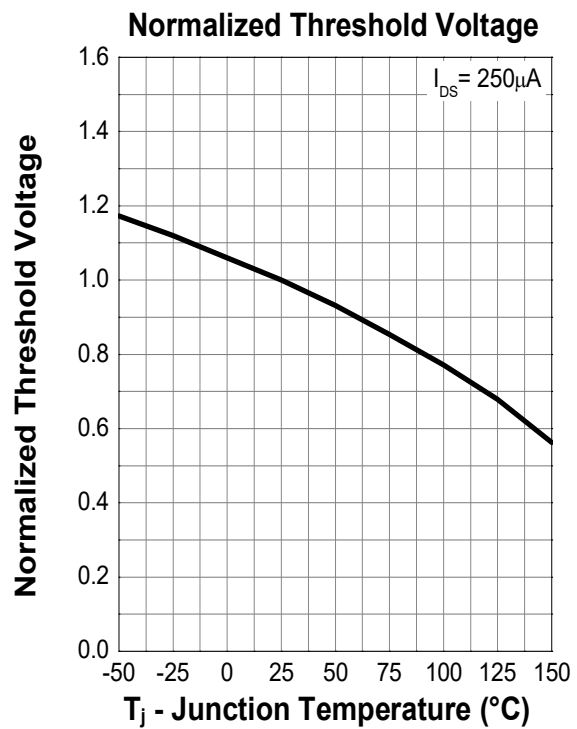
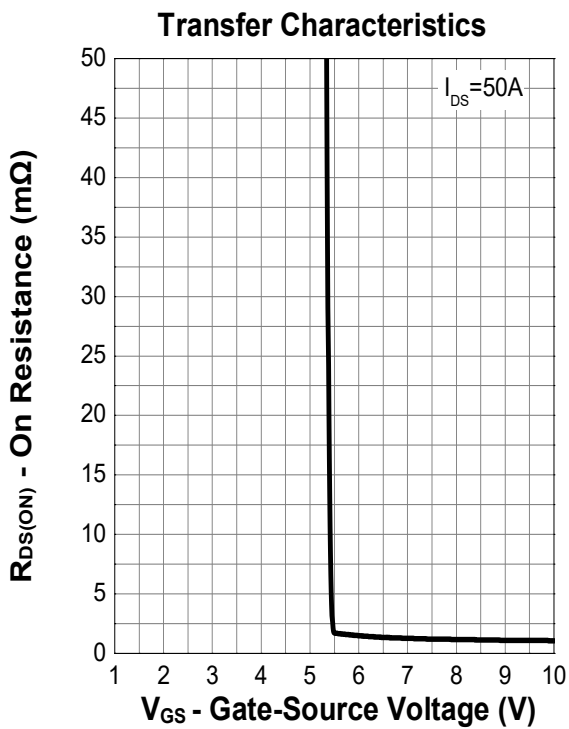
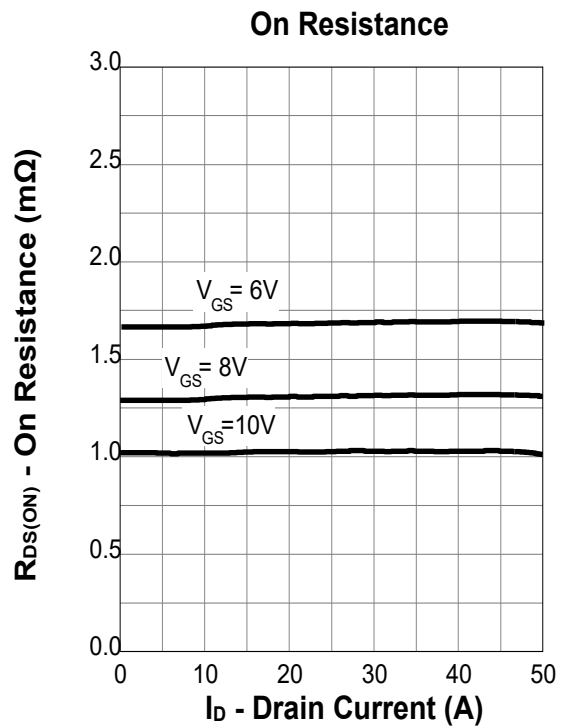
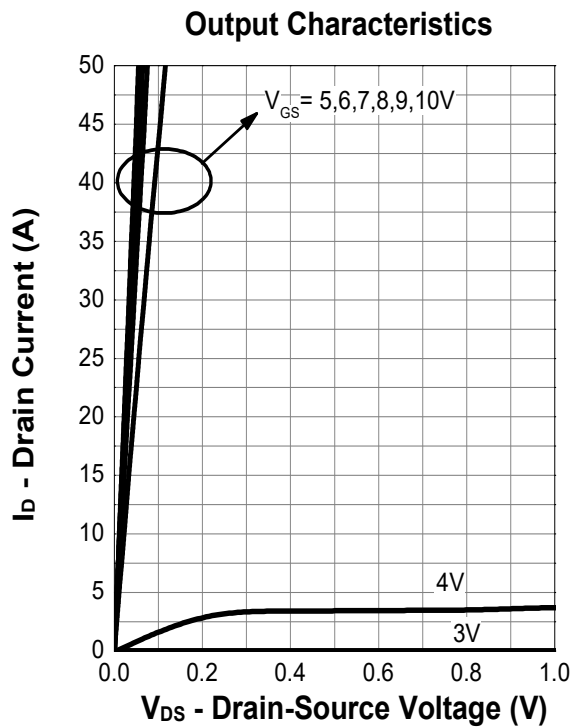

Typical Characteristics

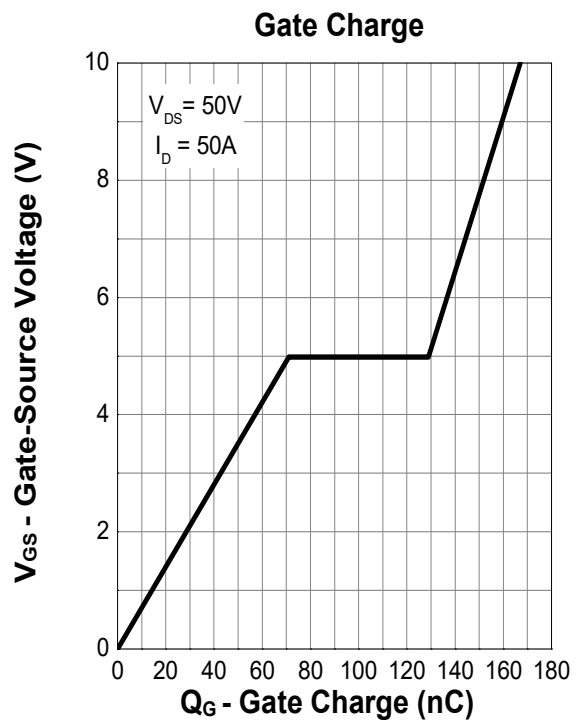
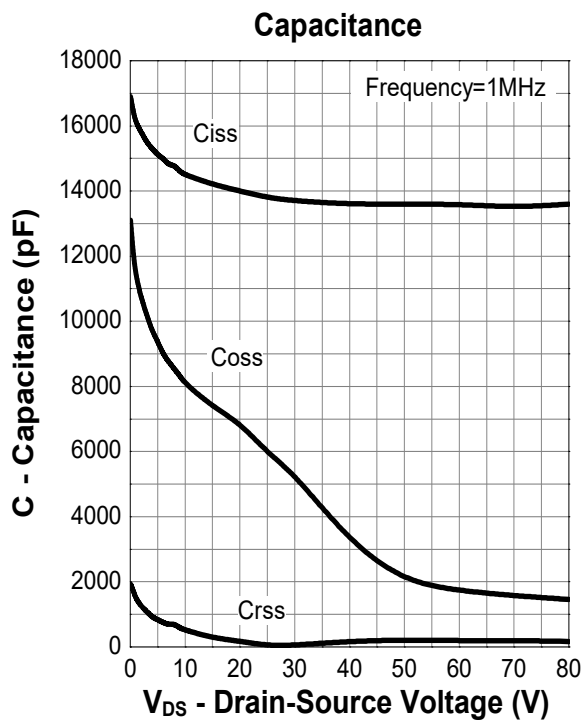
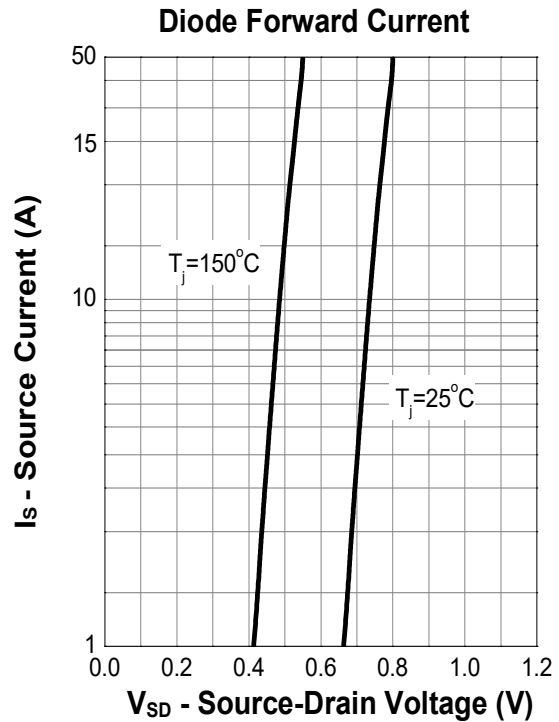
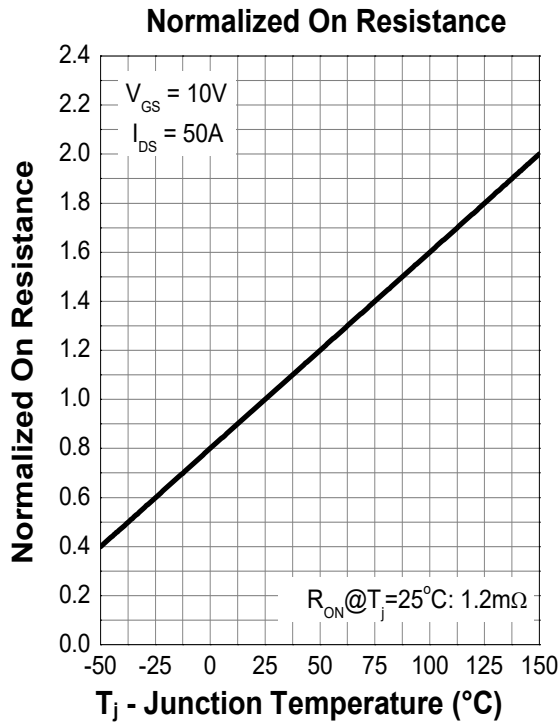

Typical Characteristics

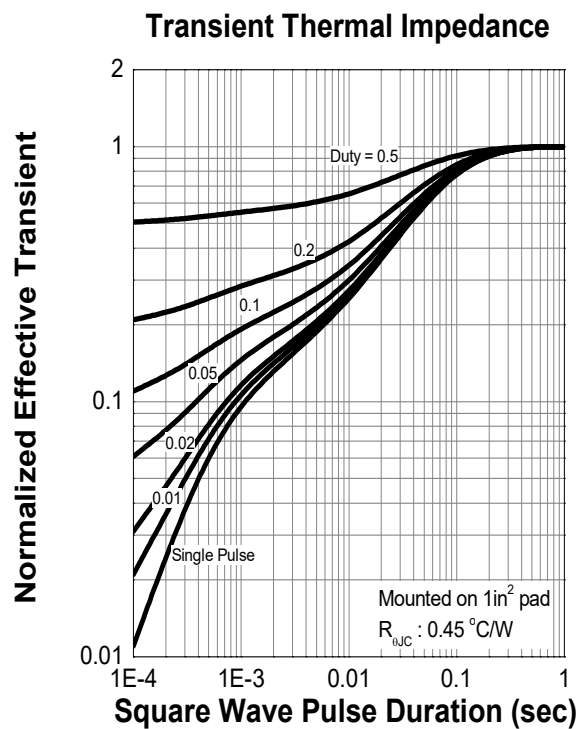
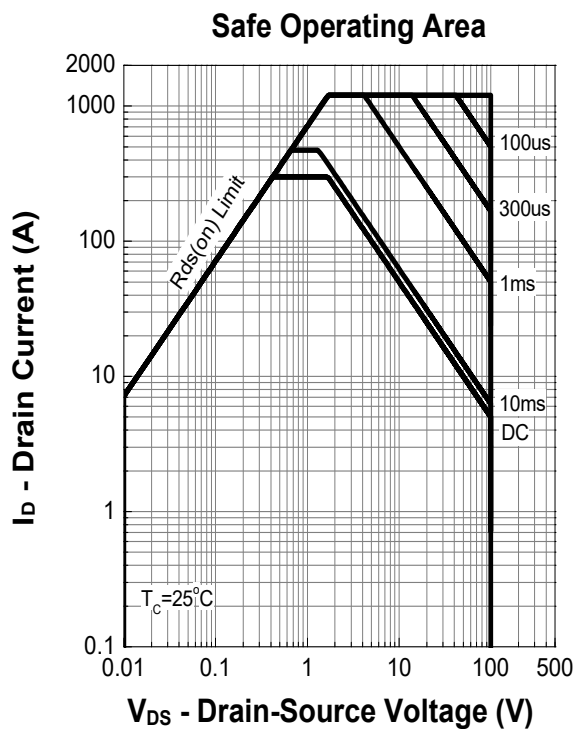
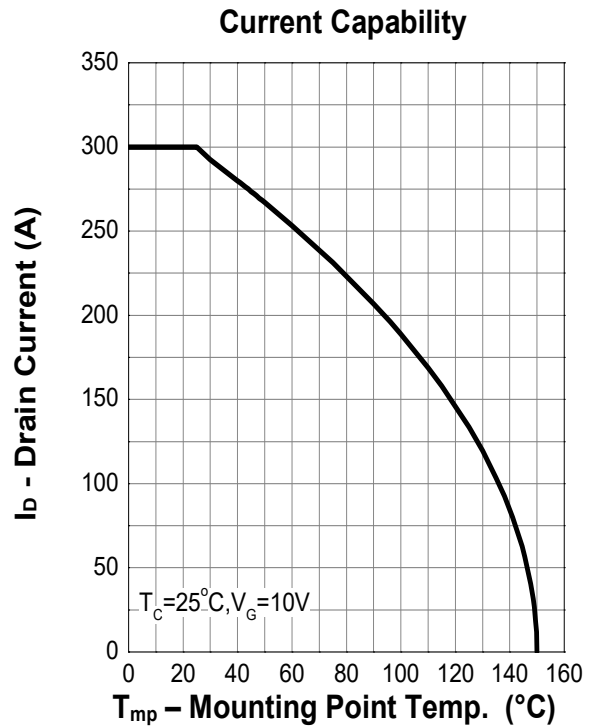
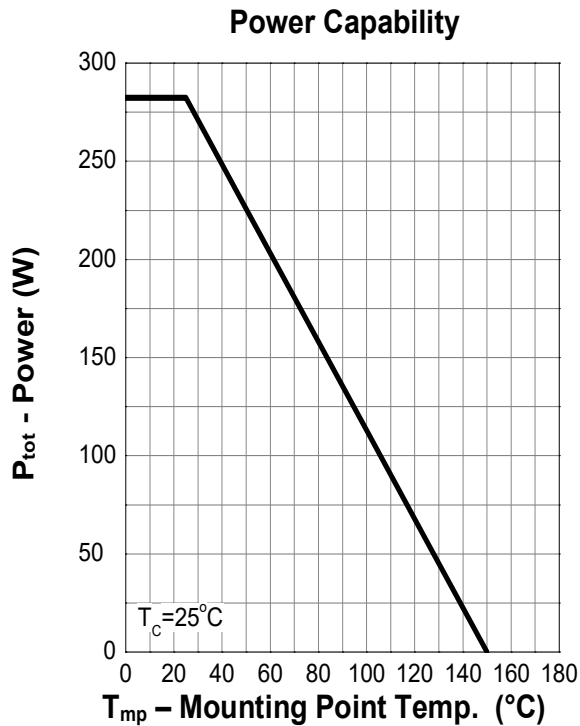

Package Dimensions

TO-263-7

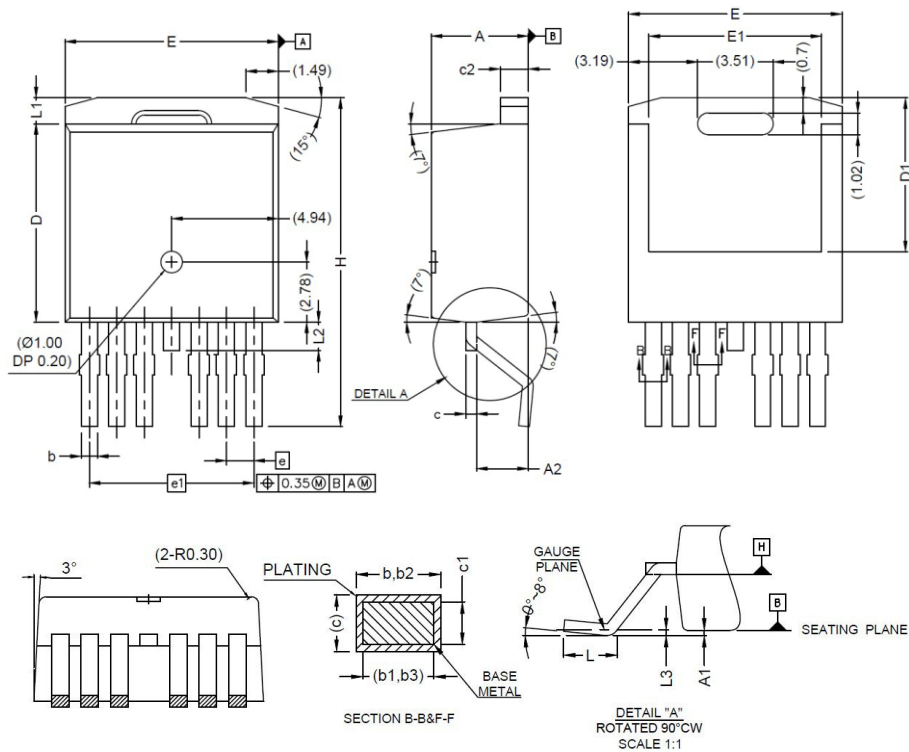

Symbol	Dimensions In Millimeters	
	MIN.	MAX.
A	4.30	4.70
A1	-	0.25
A2	2.20	2.60
b	0.65	0.85
b1	0.65	0.80
b2	0.80	1.00
b3	0.80	0.95
c	0.45	0.60
c1	0.45	0.55
c2	1.25	1.40
D	9.00	9.40
D1	6.86	7.42
E	9.68	10.08
E1	7.70	8.30
e	1.27 BSC	
e1	7.62 BSC	
L	1.78	2.79
L1	-	1.60
L2	-	1.78
L3	0.25 BSD	
H	14.61	15.88

Revision History

Revision	Release	Remark
V1.0	2023/03/07	Initial Release

Disclaimer

The information given in this document describes the independent performance of the product, but similar performance is not guaranteed under other working conditions, and cannot be guaranteed when installed with other products or equipment. To achieve the required performance of the product in actual scenarios, the customer should conduct a complete application test to assess the functionality of the product.

Allpower assumes no responsibility for equipment failures result from using products at values that exceed the ratings, operating conditions, or other parameters listed in the product specifications.

The product described in this specification is not applicable for aerospace or other applications which requires high reliability. Customers using or selling these products for use in medical, life-saving, or life-sustaining applications do so at their own risk and agree to fully indemnify.

Due to product or technical improvements, the information described or contained herein may be changed without prior notice.