

AP2716QD

N and P-Channel Enhancement Mosfet

Feature

- **N-Channel**
 $V_{DD}=40V, I_D=16A$
 $R_{DS(ON)} < 22m\Omega @ V_{GS}=10V$
 $R_{DS(ON)} < 30m\Omega @ V_{GS}=4.5V$
- **P-Channel**
 $V_{DD}=-40V, I_D=-16A$
 $R_{DS(ON)} < 44m\Omega @ V_{GS}=-10V$
 $R_{DS(ON)} < 62m\Omega @ V_{GS}=-4.5V$
- Lead free product is acquired
- High power and current handling capability
- Surface mount package

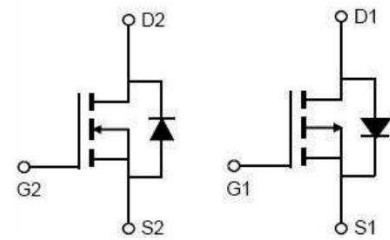

N-channel P-channel

Schematic diagram



Marking and pin assignment

Application

- PWM applications
- Load Switch
- Power management

Package Marking and Ordering Information

Device Marking	Device	Device Package	Reel Size	Tape width	Quantity (PCS)
2716QD	AP2716QD	PDFN3*3-8L	13 inch	-	5000

ABSOLUTE MAXIMUM RATINGS ($T_a=25^\circ\text{C}$ unless otherwise noted)

Parameter	Symbol	N-Channel	P-Channel	Unit
Drain-Source Voltage	V_{DS}	40	-40	V
Gate-Source Voltage	V_{GS}	± 20	± 20	V
Continuous Drain Current ($T_a = 25^\circ\text{C}$)	I_D	16	-16	A
Continuous Drain Current ($T_a = 100^\circ\text{C}$)	I_D	10.2	-10.2	A
Pulsed Drain Current ⁽¹⁾	I_{DM}	40	-40	A
Power Dissipation	P_D	21		W
Thermal Resistance from Junction to Ambient	$R_{\theta JA}$	6.25		$^\circ\text{C}/\text{W}$
Junction Temperature	T_J	150		$^\circ\text{C}$
Storage Temperature	T_{STG}	-55~ +150		$^\circ\text{C}$

N-CH ELECTRICAL CHARACTERISTICS(T_a=25°C unless otherwise noted)

Parameter	Symbol	Test Condition	Min	Type	Max	Unit
Static Characteristics						
Drain-source breakdown voltage	V _{(BR)DSS}	V _{GS} = 0V, I _D = -250μA	40			V
Zero gate voltage drain current	I _{DSS}	V _{DS} = 100V, V _{GS} = 0V			1	μA
Gate-body leakage current	I _{GSS}	V _{GS} = ±20V, V _{DS} = 0V			±100	nA
Gate threshold voltage ⁽²⁾	V _{GS(th)}	V _{DS} = V _{GS} , I _D = 250μA	1	1.6	2.5	V
Drain-source on-resistance ⁽²⁾	R _{DS(on)}	V _{GS} = 10V, I _D = 10A		17	22	mΩ
		V _{GS} = 4.5V, I _D = 6A		22	30	
Dynamic characteristics						
Input Capacitance	C _{iss}	V _{DS} = 20V, V _{GS} = 0V, f = 1MHz		1050		pF
Output Capacitance	C _{oss}			84		
Reverse Transfer Capacitance	C _{rss}			72		
Switching characteristics						
Turn-on delay time	t _{d(on)}	V _{DD} = 20V, I _D = 5A, R _L = 6Ω V _{GS} = 10V, R _G = 1Ω		11		ns
Turn-on rise time	t _r			13		
Turn-off delay time	t _{d(off)}			36		
Turn-off fall time	t _f			9		
Total Gate Charge	Q _g	V _{DS} = 20V, I _D = 5A, V _{GS} = 10V		11		nC
Gate-Source Charge	Q _{gs}			1.9		
Gate-Drain Charge	Q _{gd}			2.2		
Source-Drain Diode characteristics						
Diode Forward voltage ⁽²⁾	V _{DS}	V _{GS} = 0V, I _S = 10A			1.2	V
Diode Forward current ⁽³⁾	I _S		-	-	10	A

P-CH ELECTRICAL CHARACTERISTICS(T_a=25°C unless otherwise noted)

Parameter	Symbol	Test Condition	Min	Type	Max	Unit
Static Characteristics						
Drain-source breakdown voltage	V _{(BR)DSS}	V _{GS} = 0V, I _D = -250μA	-40			V
Zero gate voltage drain current	I _{DSS}	V _{DS} = 100V, V _{GS} = 0V			1	μA
Gate-body leakage current	I _{GSS}	V _{GS} = ±20V, V _{DS} = 0V			±100	nA
Gate threshold voltage ⁽²⁾	V _{GS(th)}	V _{DS} = V _{GS} , I _D = -250μA	-1	-1.7	-2.5	V
Drain-source on-resistance ⁽²⁾	R _{DS(on)}	V _{GS} = -10V, I _D = -10A		35	44	mΩ
		V _{GS} = -4.5V, I _D = -6A		48	60	
Dynamic characteristics						
Input Capacitance	C _{iss}	V _{DS} = -20V, V _{GS} = 0V, f = 1MHz		1160		pF
Output Capacitance	C _{oss}			155		
Reverse Transfer Capacitance	C _{rss}			98		
Switching characteristics						
Turn-on delay time	t _{d(on)}	V _{DD} = -20V, I _D = -5A, R _L = 6Ω V _{GS} = -10V, R _G = 1Ω		8		ns
Turn-on rise time	t _r			15		
Turn-off delay time	t _{d(off)}			23		
Turn-off fall time	t _f			9		
Total Gate Charge	Q _g	V _{DS} = -20V, I _D = -5A, V _{GS} = -10V		20		nC
Gate-Source Charge	Q _{gs}			3.5		
Gate-Drain Charge	Q _{gd}			4.2		
Source-Drain Diode characteristics						
Diode Forward voltage ⁽²⁾	V _{DS}	V _{GS} = 0V, I _S = -10A			1.2	V
Diode Forward current ⁽³⁾	I _S		-	-	-10	A

Notes:

1. Repetitive Rating: pulse width limited by maximum junction temperature
2. Pulse Test: pulse width ≤ 300μs, duty cycle ≤ 2%
3. Surface Mounted on FR4 Board, t ≤ 10 sec

N-Channel

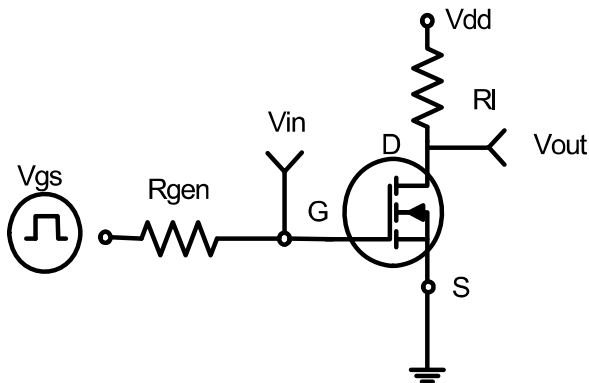

Figure 1: Switching Test Circuit

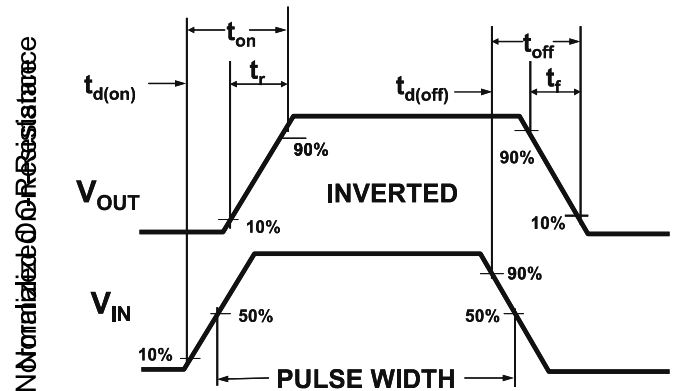

Figure 2: Switching Waveforms

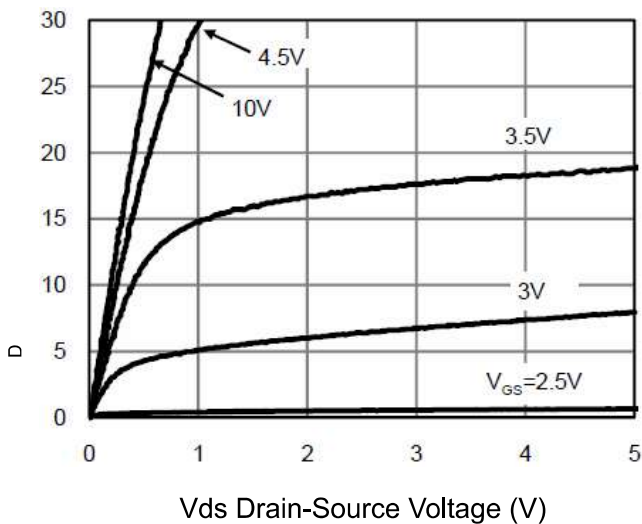

Figure 3 Output Characteristics

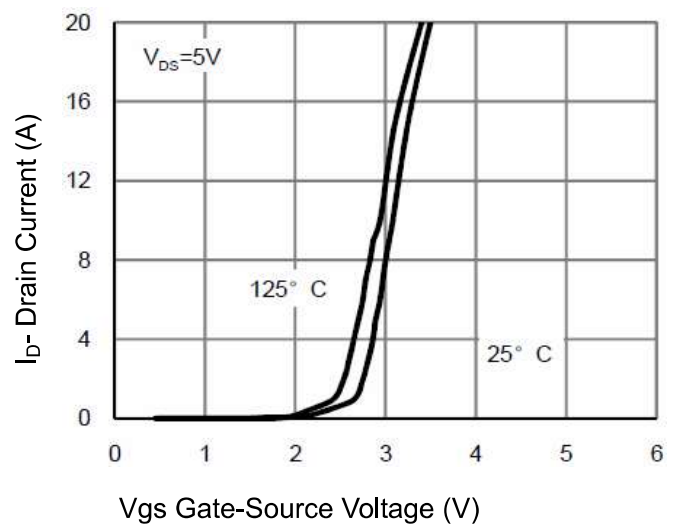

Figure 4 Transfer Characteristics

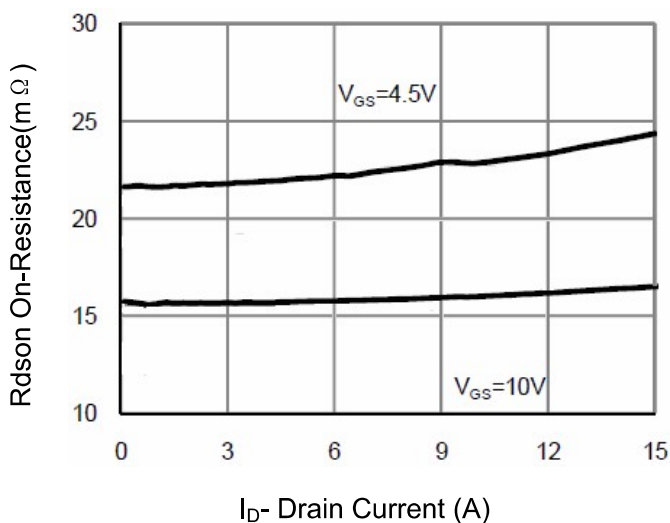

Figure 5 Drain-Source On-Resistance

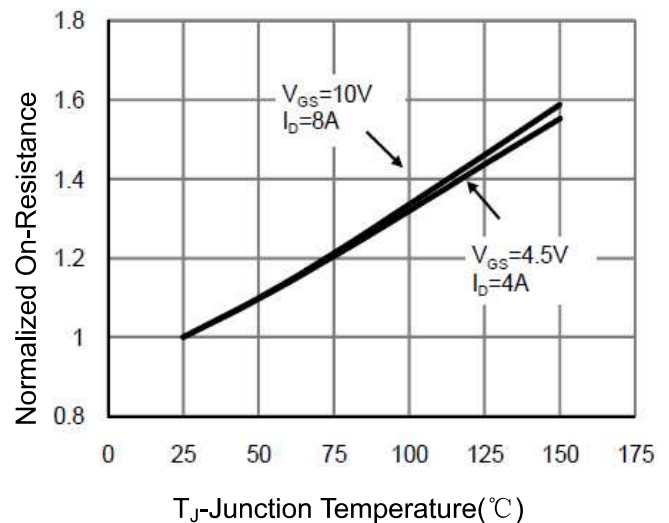
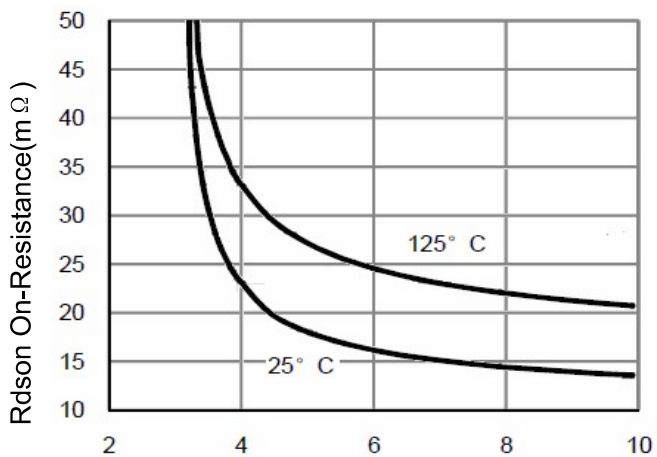
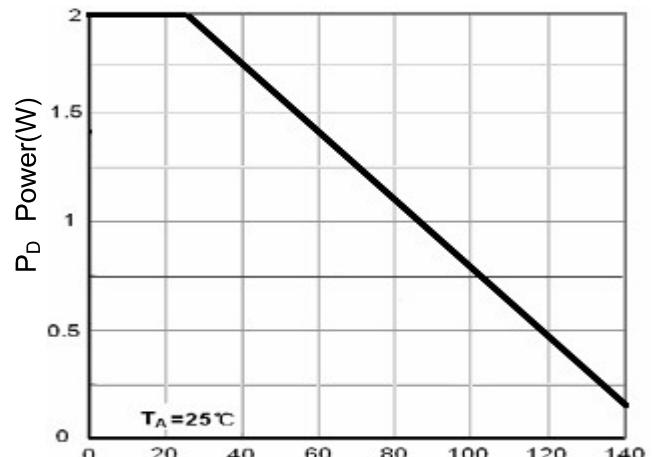

Figure 6 Drain-Source On-Resistance



Vgs Gate-Source Voltage (V)
Figure 7 Rdson vs Vgs



T_J-Junction Temperature(°C)
Figure 8 Power Dissipation

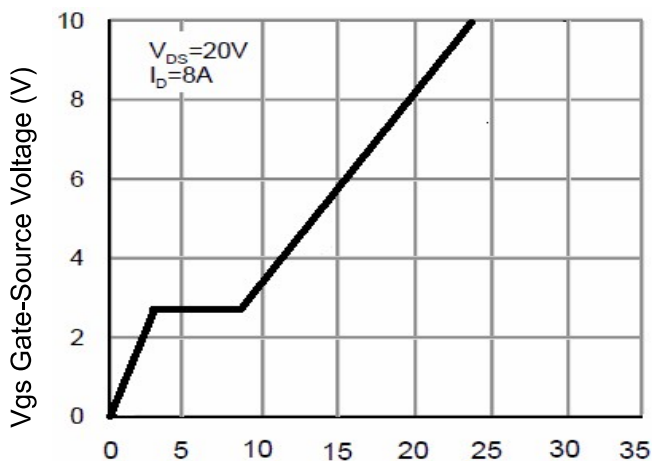

Qg Gate Charge (nC)
Figure 9 Gate Charge

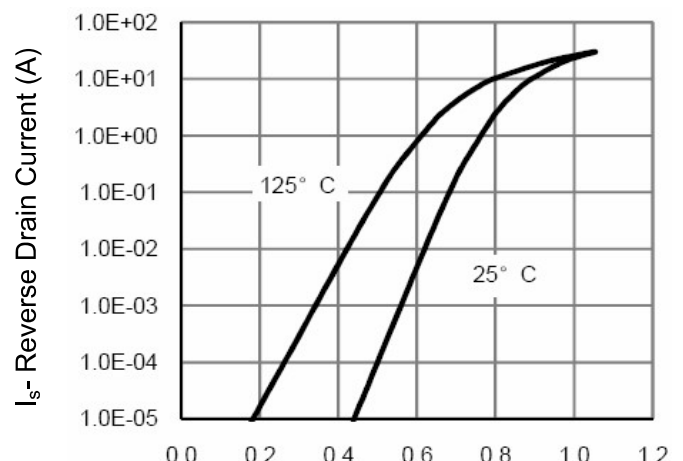

Vds Drain-Source Voltage (V)
Figure 10 Source- Drain Diode Forward

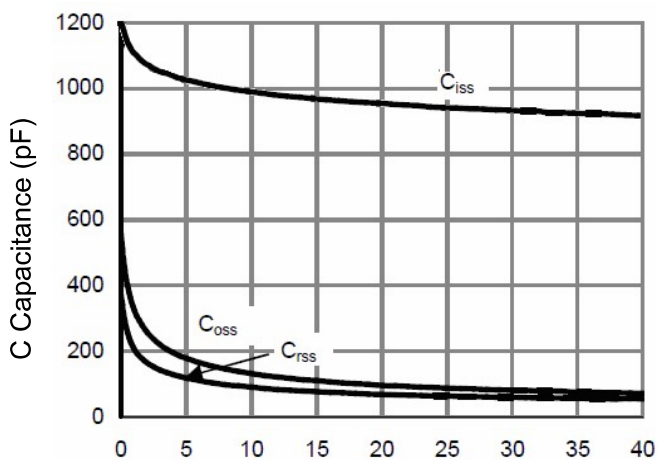

Vds Drain-Source Voltage (V)
Figure 11 Capacitance vs Vds

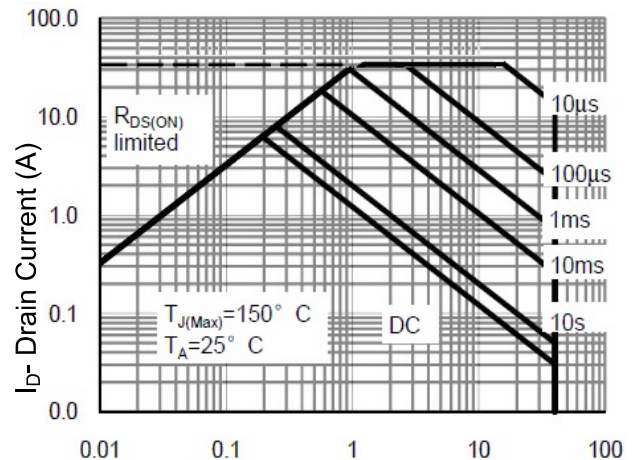

Vds Drain-Source Voltage (V)
Figure 12 Safe Operation Area

P-Channel

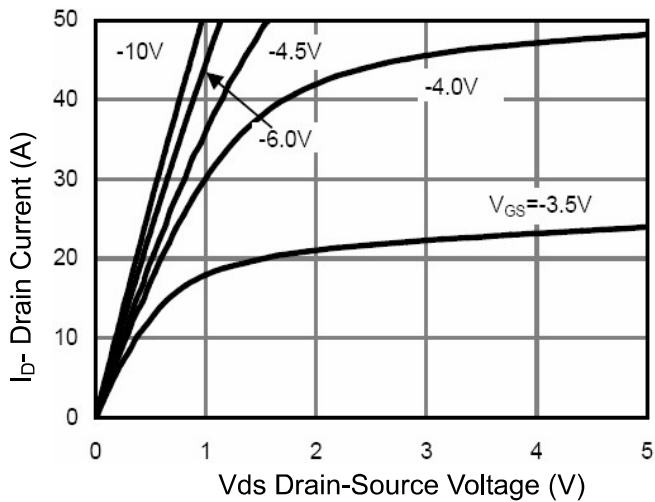

Figure 1 Output Characteristics

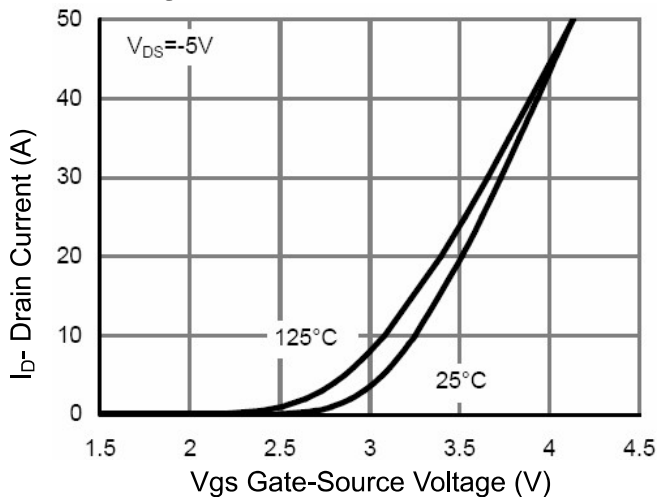

Figure 2 Transfer Characteristics

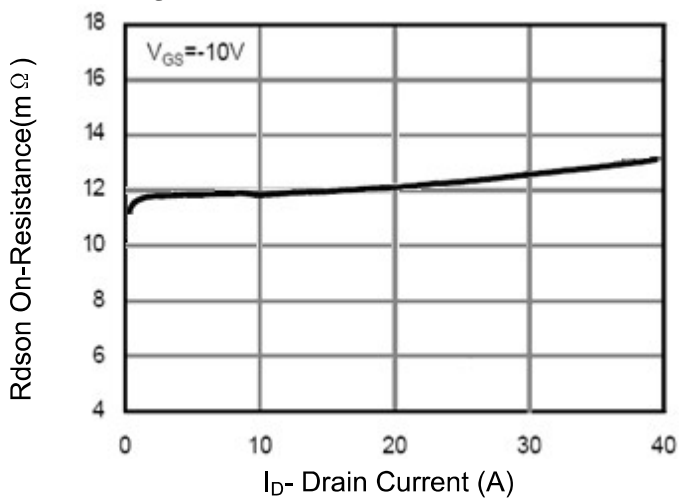

Figure 3 Rdson- Drain Current

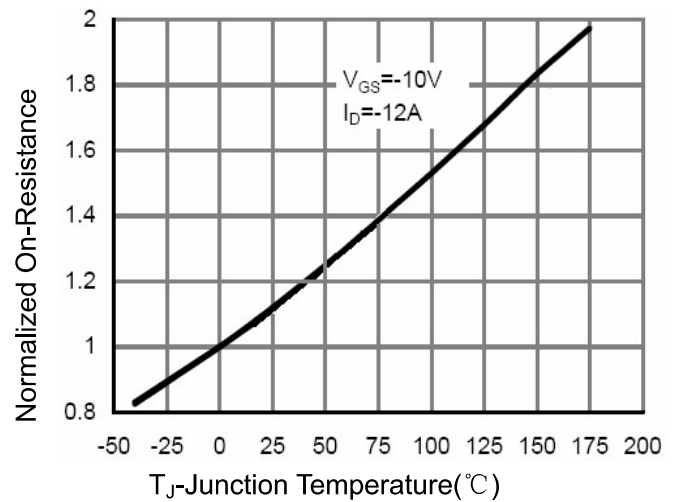

Figure 4 Rdson-Junction Temperature

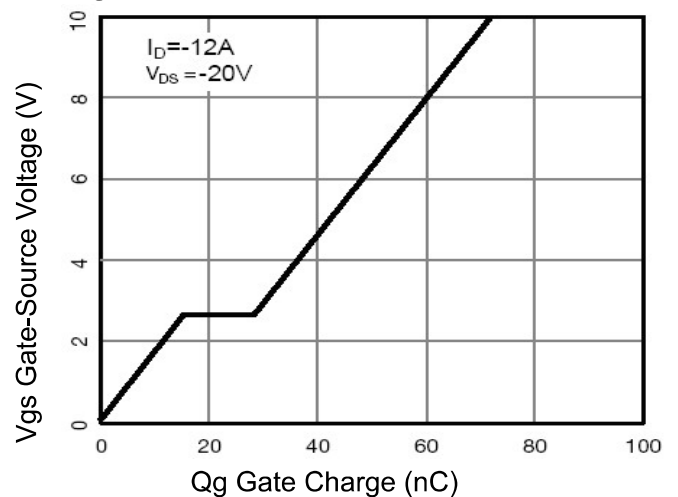

Figure 5 Gate Charge

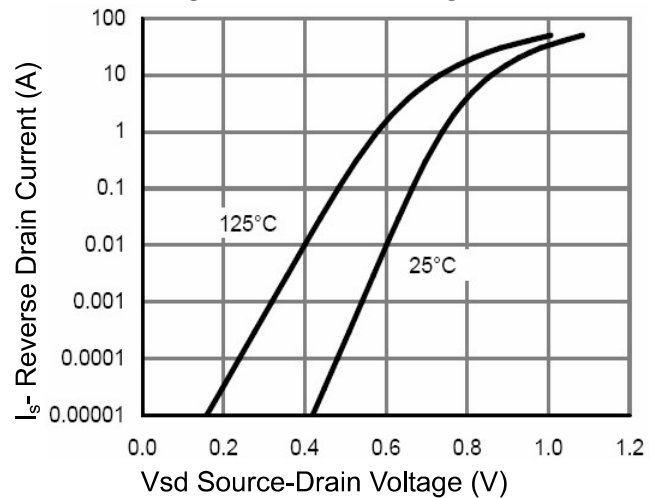

Figure 6 Source- Drain Diode Forward

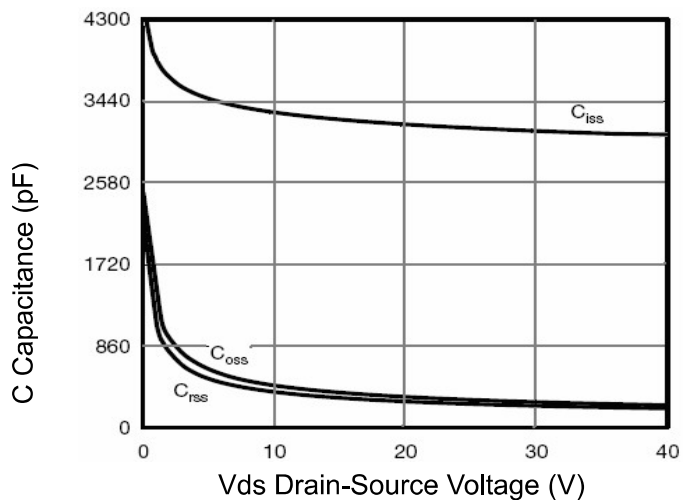

Figure 7 Capacitance vs Vds

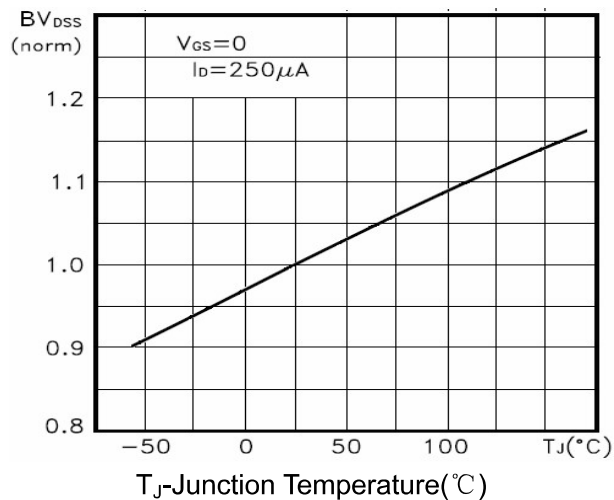

Figure 9 BV_{DSS} vs Junction Temperature

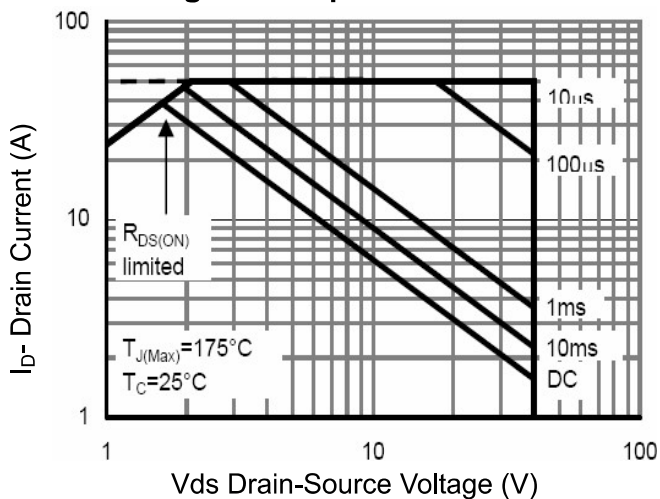

Figure 8 Safe Operation Area

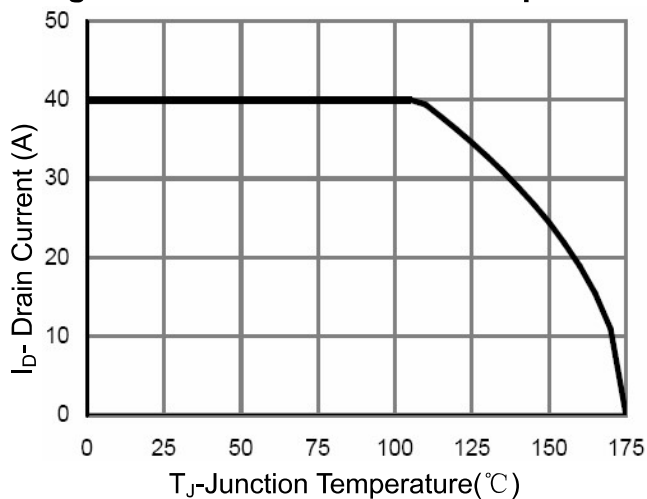

Figure 10 ID Current Derating vs Junction Temperature

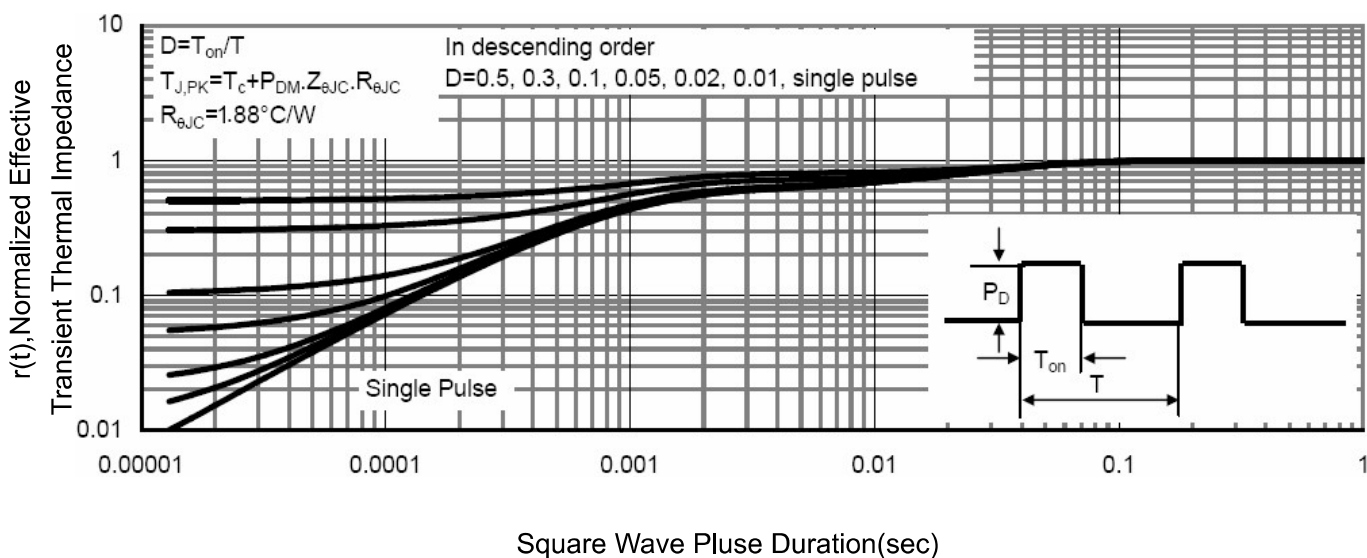

Figure 11 Normalized Maximum Transient Thermal Impedance

PACKAGE OUTLINE DIMENSIONS

