

# AP30P06G

P-Channel Enhancement Mosfet

# AIPOWER

## DATA SHEET

### Feature

- -60V,-30A  
 $R_{DS(ON)} < 30m\Omega @ V_{GS} = -10V$  TYP:23 m $\Omega$   
 $R_{DS(ON)} < 38m\Omega @ V_{GS} = -4.5V$  TYP:27 m $\Omega$
- Advanced Trench Technology
- Lead free product is acquired
- Excellent  $R_{DS(ON)}$  and Low Gate Charge

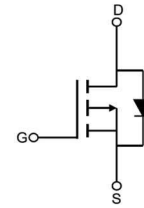

### Application

- PWM applications
- Load Switch
- Power management

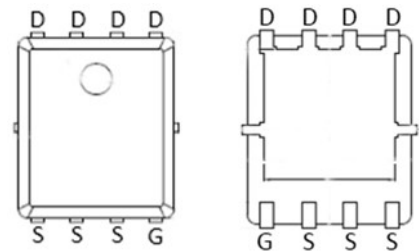

PDFN5X6-8L

### Package Marking and Ordering Information

Device Marking	Device	Device Package	Reel Size	Tape width	Quantity (PCS)
30P06G	AP30P06K	PDFN5*6-8L	13 inch	-	5000

### ABSOLUTE MAXIMUM RATINGS ( $T_a=25^\circ\text{C}$ unless otherwise noted)

Parameter	Symbol	Value	Unit
Drain-Source Voltage	$V_{DS}$	-60	V
Gate-Source Voltage	$V_{GS}$	$\pm 20$	V
Continuous Drain Current ( $T_a=25^\circ\text{C}$ )	$I_D$	-30	A
Continuous Drain Current ( $T_a=100^\circ\text{C}$ )	$I_D$	-20	A
Pulsed Drain Current <sup>(1)</sup>	$I_{DM}$	-120	A
Singel Pulsed Avalanche Energy <sup>(2)</sup>	$E_{AS}$	90	mJ
Power Dissipation	$P_D$	35	W
Thermal Resistance from Junction to Case	$R_{\theta JC}$	3.8	$^\circ\text{C}/\text{W}$
Junction Temperature	$T_J$	150	$^\circ\text{C}$
Storage Temperature	$T_{STG}$	-55~ +150	$^\circ\text{C}$

MOSFET ELECTRICAL CHARACTERISTICS( $T_a=25^\circ\text{C}$  unless otherwise noted)

Parameter	Symbol	Test Condition	Min	Type	Max	Unit
<b>Static Characteristics</b>						
Drain-source breakdown voltage	$V_{(BR)DSS}$	$V_{GS} = 0V, I_D = -250\mu A$	-60	-	-	V
Zero gate voltage drain current	$I_{DSS}$	$V_{DS} = -60V, V_{GS} = 0V$	-	-	1	$\mu A$
Gate-body leakage current	$I_{GSS}$	$V_{GS} = \pm 20V, V_{DS} = 0V$	-	-	$\pm 100$	nA
Gate threshold voltage <sup>(3)</sup>	$V_{GS(th)}$	$V_{DS} = V_{GS}, I_D = -250\mu A$	-1	-1.7	-2.5	V
Drain-source on-resistance <sup>(3)</sup>	$R_{DS(on)}$	$V_{GS} = -10V, I_D = -15A$	-	23	30	m $\Omega$
		$V_{GS} = -4.5V, I_D = -10A$	-	27	38	
<b>Dynamic characteristics</b>						
Input Capacitance	$C_{iss}$	$V_{DS} = -25V, V_{GS} = 0V, f = 1MHz$	-	2400	-	pF
Output Capacitance	$C_{oss}$		-	251	-	
Reverse Transfer Capacitance	$C_{rss}$		-	196	-	
<b>Switching characteristics</b>						
Turn-on delay time	$t_{d(on)}$	$V_{DD} = -30V, I_D = -30A, R_L = 3\Omega$ $V_{GS} = -10V, R_G = 3\Omega$	-	15	-	ns
Turn-on rise time	$t_r$		-	120	-	
Turn-off delay time	$t_{d(off)}$		-	245	-	
Turn-off fall time	$t_f$		-	199	-	
Total Gate Charge	$Q_g$	$V_{DS} = -30V, I_D = -15A,$ $V_{GS} = -10V$	-	49	-	nC
Gate-Source Charge	$Q_{gs}$		-	8	-	
Gate-Drain Charge	$Q_{gd}$		-	12	-	
<b>Source-Drain Diode characteristics</b>						
Diode Forward voltage <sup>(2)</sup>	$V_{DS}$	$V_{GS} = 0V, I_S = -10A$	-	-	-1.2	V
Diode Forward current <sup>(3)</sup>	$I_S$		-	-	-30	A

**Notes:**

1. Repetitive Rating: pulse width limited by maximum junction temperature
2. EAS Condition:  $T_J = 25^\circ\text{C}, V_{DD} = -30V, R_G = 20\Omega, L = 0.5\text{mH}$
3. Pulse Test: pulse width  $\leq 300\mu\text{s}$ , duty cycle  $\leq 2\%$
4. Surface Mounted on FR4 Board,  $t \leq 10\text{ sec}$

**Test Circuit**

Gate Charge Test Circuit & Waveform

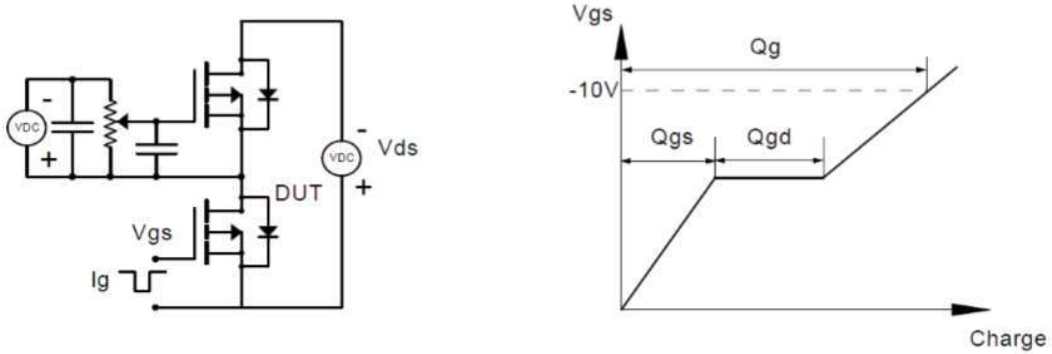

Resistive Switching Test Circuit & Waveforms

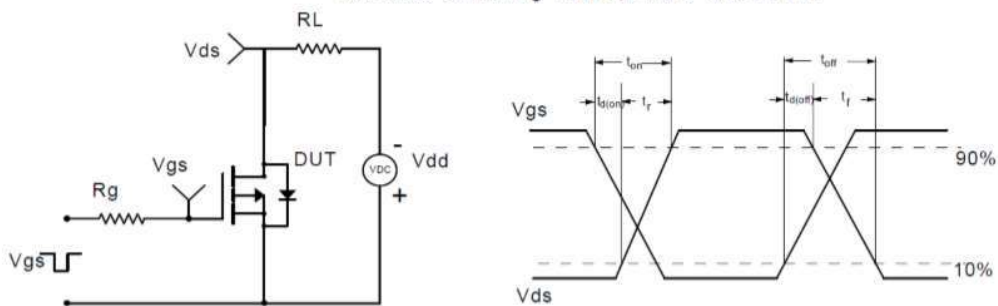

Unclamped Inductive Switching (UIS) Test Circuit & Waveforms

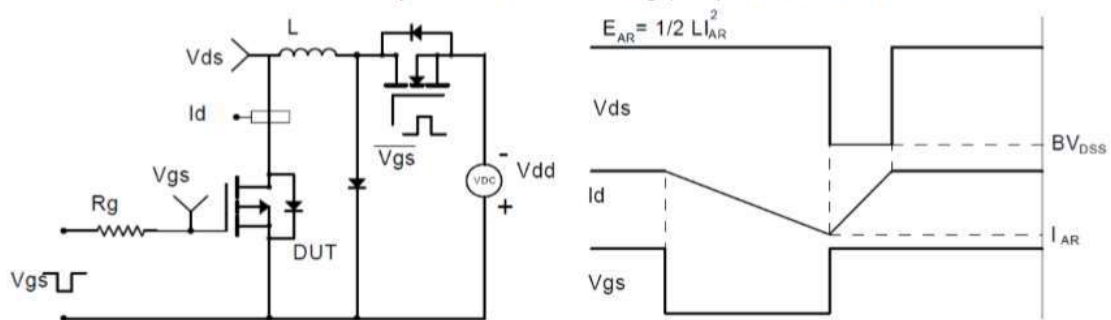

Diode Recovery Test Circuit & Waveforms

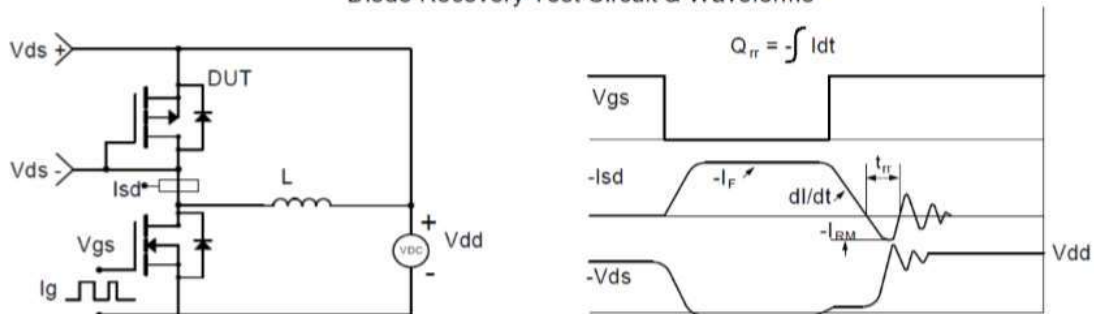

**Typical Performance Characteristics**

**Figure 1: Output Characteristics**

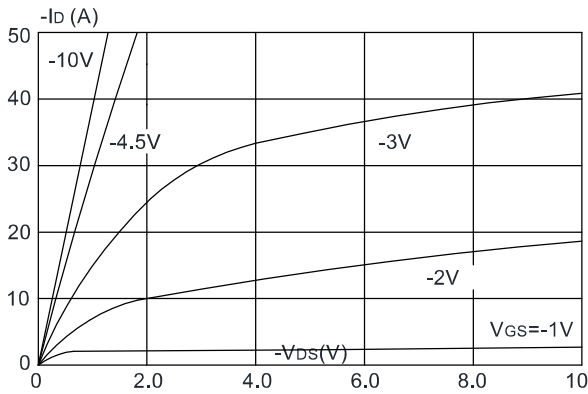

**Figure 2: Typical Transfer Characteristics**

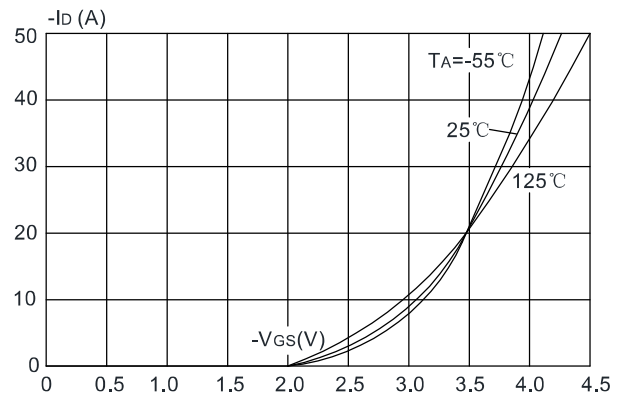

**Figure 3: On-resistance vs. Drain Current**

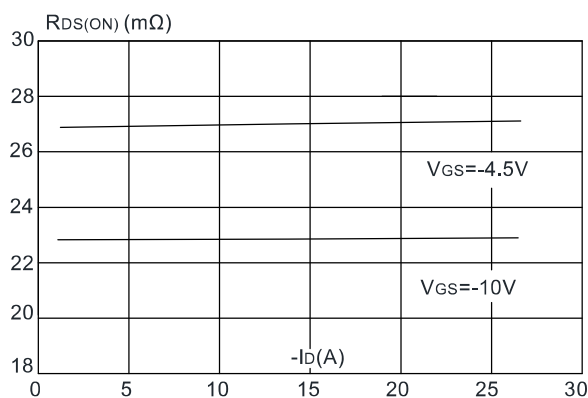

**Figure 4: Body Diode Characteristics**

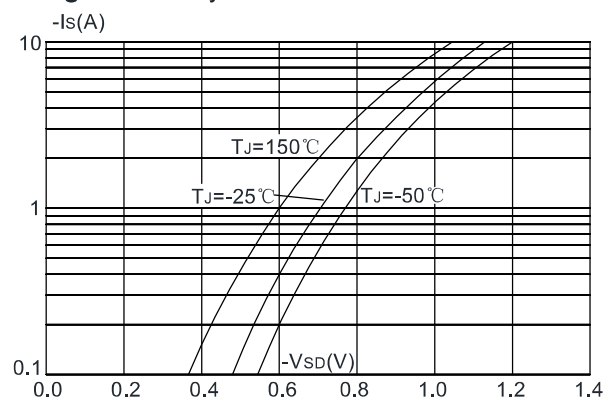

**Figure 5: Gate Charge Characteristics**

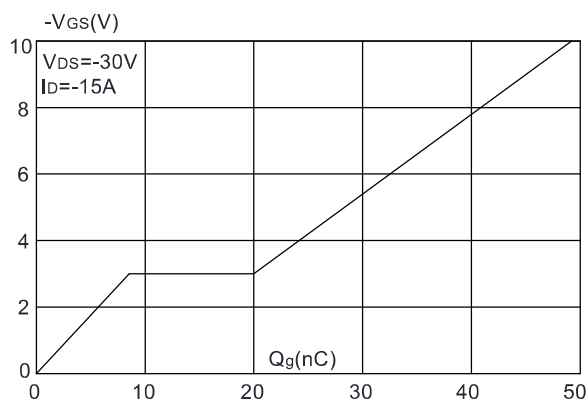

**Figure 6: Capacitance Characteristics**

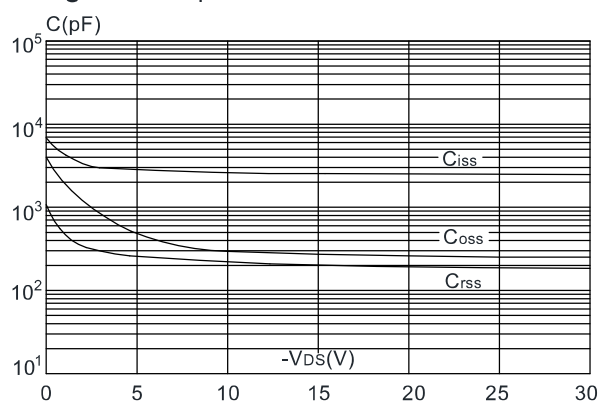

**Figure 7: Normalized Breakdown Voltage vs. Junction Temperature**

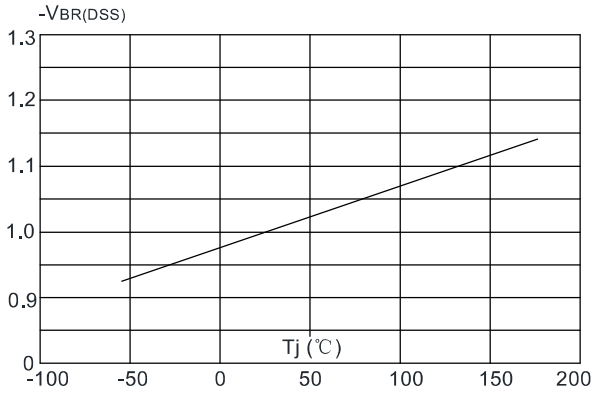

**Figure 8: Normalized on Resistance vs. Junction Temperature**

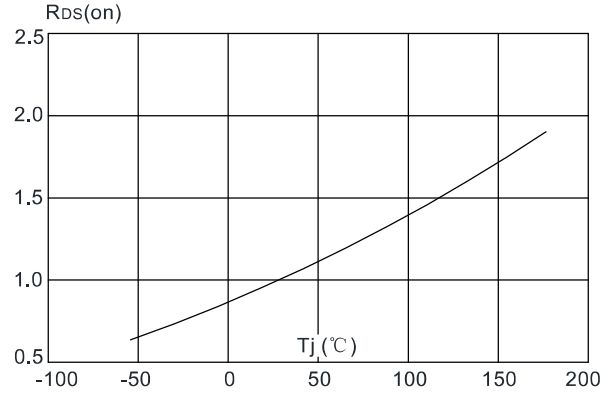

**Figure 9: Maximum Safe Operating Area**

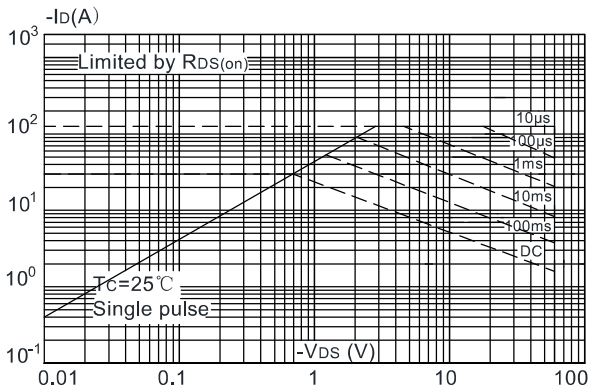

**Figure 10: Maximum Continuous Drain Current vs. Case Temperature**

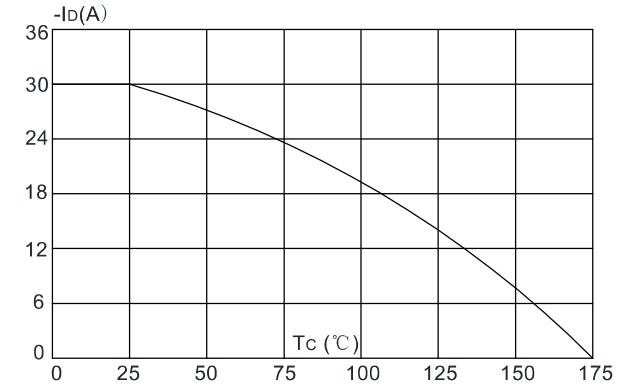

**Figure.11: Maximum Effective Transient Thermal Impedance, Junction-to-Case**

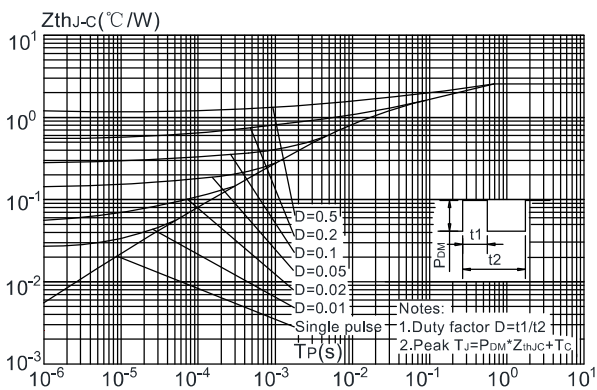

# AP30P06G

P-Channel Enhancement Mosfet

### PDFN5\*6-8L Package Information

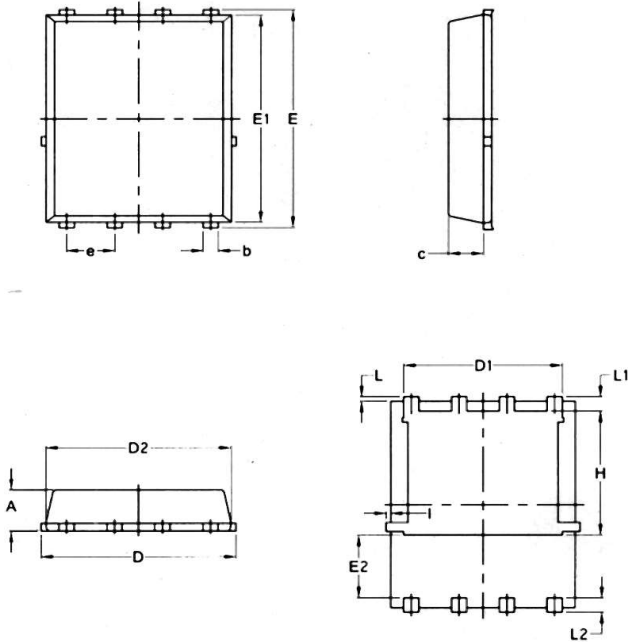

PDFN5X6-8L

SYMBOL	COMMON			
	MM		INCH	
	MIN.	MAX.	MIN.	MAX.
A	1.03	1.17	0.0406	0.0461
b	0.34	0.48	0.0134	0.0189
c	0.824	0.970	0.0324	0.0382
D	4.80	5.40	0.1890	0.2126
D1	4.11	4.31	0.1618	0.1697
D2	4.80	5.00	0.1890	0.1969
E	5.95	6.15	0.2343	0.2421
E1	5.65	5.85	0.2224	0.2303
E2	1.60	—	0.0630	—
e	1.27 BSC		0.05 BSC	
L	0.05	0.25	0.0020	0.0098
L1	0.38	0.50	0.0150	0.0197
L2	0.38	0.50	0.0150	0.0197
H	3.30	3.50	0.1299	0.1378
I	—	0.18	—	0.0070